

SWL SERIES

- ★ 三层高密分子涂漆，
隔绝灰尘更耐高温。
- ★ 高端滚珠轴承，
减少摩擦提升传动效率。
- ★ 优质合金钢精密磨齿，
提高啮合精度保证品质。

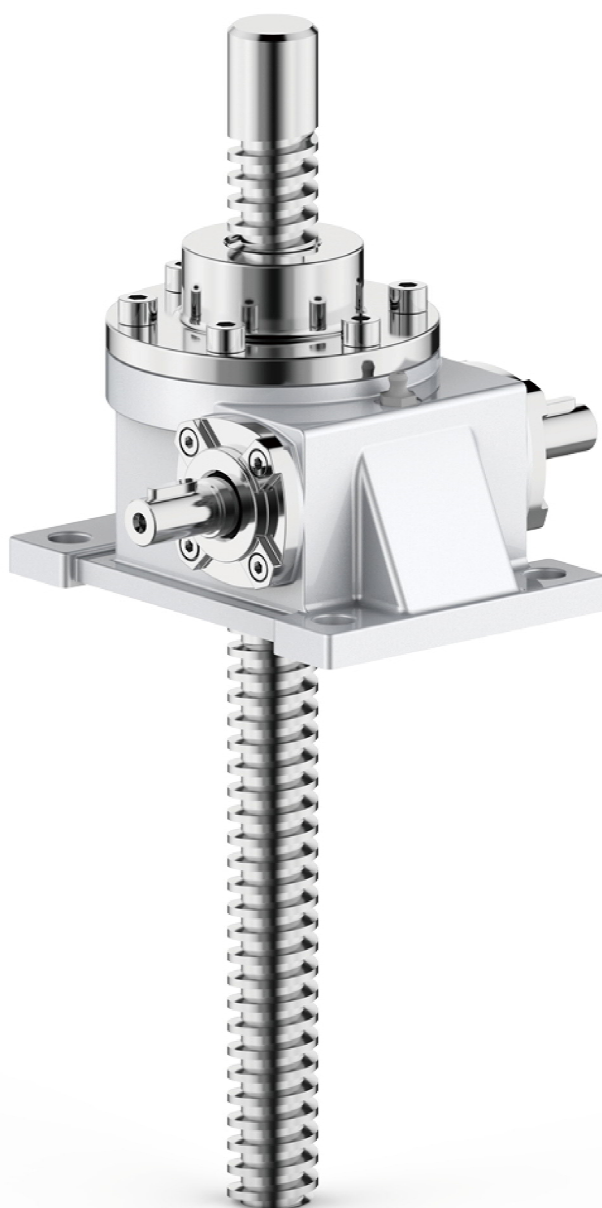

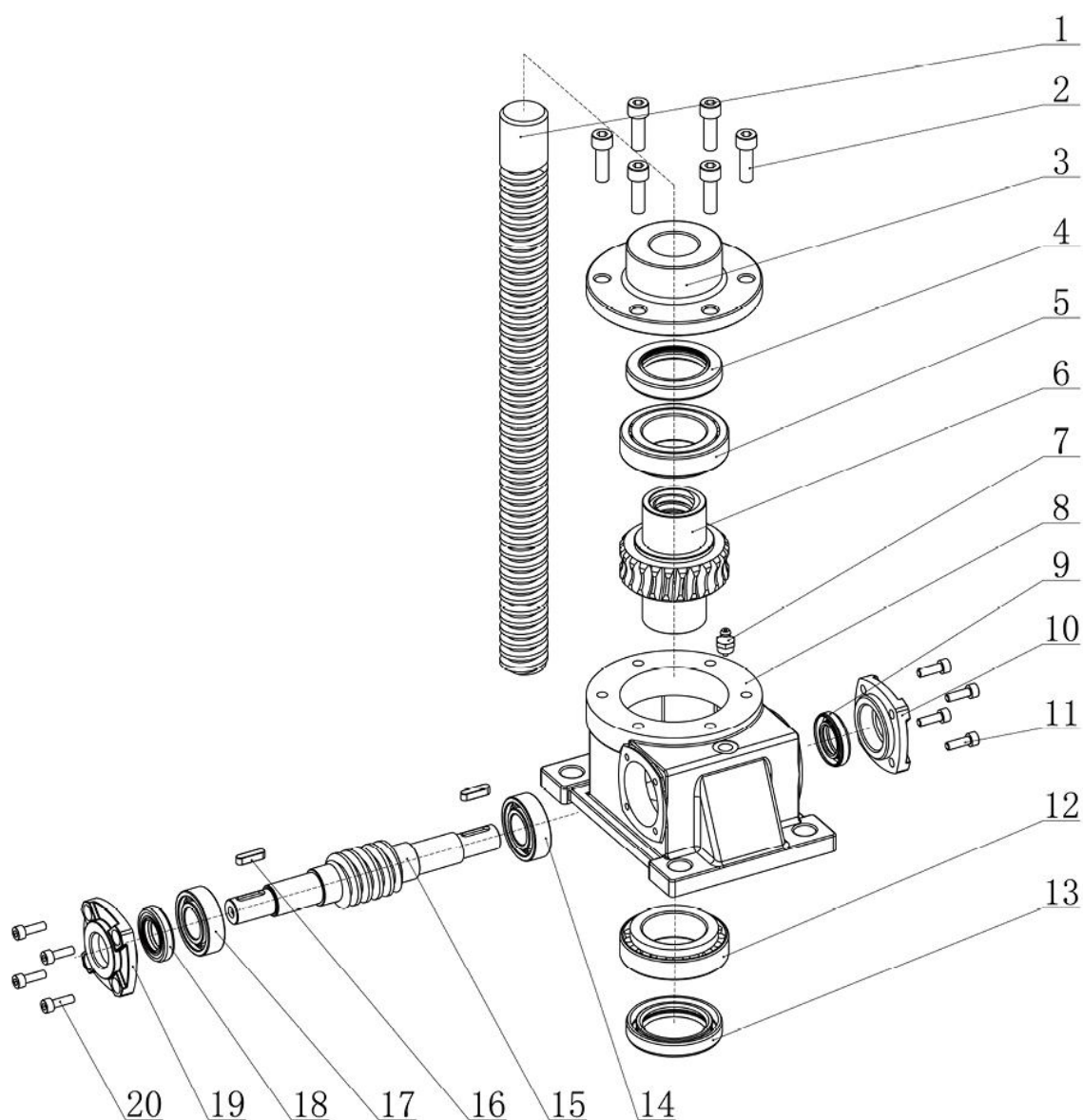

SWL系列爆炸图

1.丝杆	6.蜗轮	11.螺钉	16.平键
2.螺钉	7.油嘴	12.轴承	17.轴承
3.箱盖	8.箱体	13.骨架油封	18.骨架油封
4.骨架油封	9.骨架油封	14.轴承	19.端盖
5.轴承	10.端盖	15.蜗杆	20.螺钉

YFSWL系列蜗轮丝杆升降机

YFSWL Series Worm Screw Rod Lifter



325

蜗轮丝杆升降机/WORM SCREW ROD LIFTER

YFSWL 升降机，本升降机是由蜗轮副和梯形丝杆组合来完成物件的提升和下降，本机具有结构紧凑，体小轻便、灵活、可靠、寿命长、安装方便。在静止时还可自锁。

Consists of worm unit and echeion boft for firing up or moving down,Compecf in structure,light and portable,flexible,refiable,long in service life,easy to installation,and self-iocking while stopping.

技术参数/TECHNICAL DATA

型号/Model	SWL1.0	SWL2.5	SWL5	SWL10	SWL15	SWL20	SWL25	SWL35	SWL50	SWL75	SWL100
最大起升力 (kN) Max lifting Force	10	25	50	100	150	200	250	350	500	750	1000
丝杆螺纹尺寸 Bolt Thread Size	Tr22×5	Tr30×8	Tr42×8	Tr58×12		Tr65×12	Tr90×16	Tr110×16	Tr120×16	Tr130×18	Tr150×24
最大拉力 (kN) Max Tansion	10	25	50	100	150	200	250	350	500	750	1000

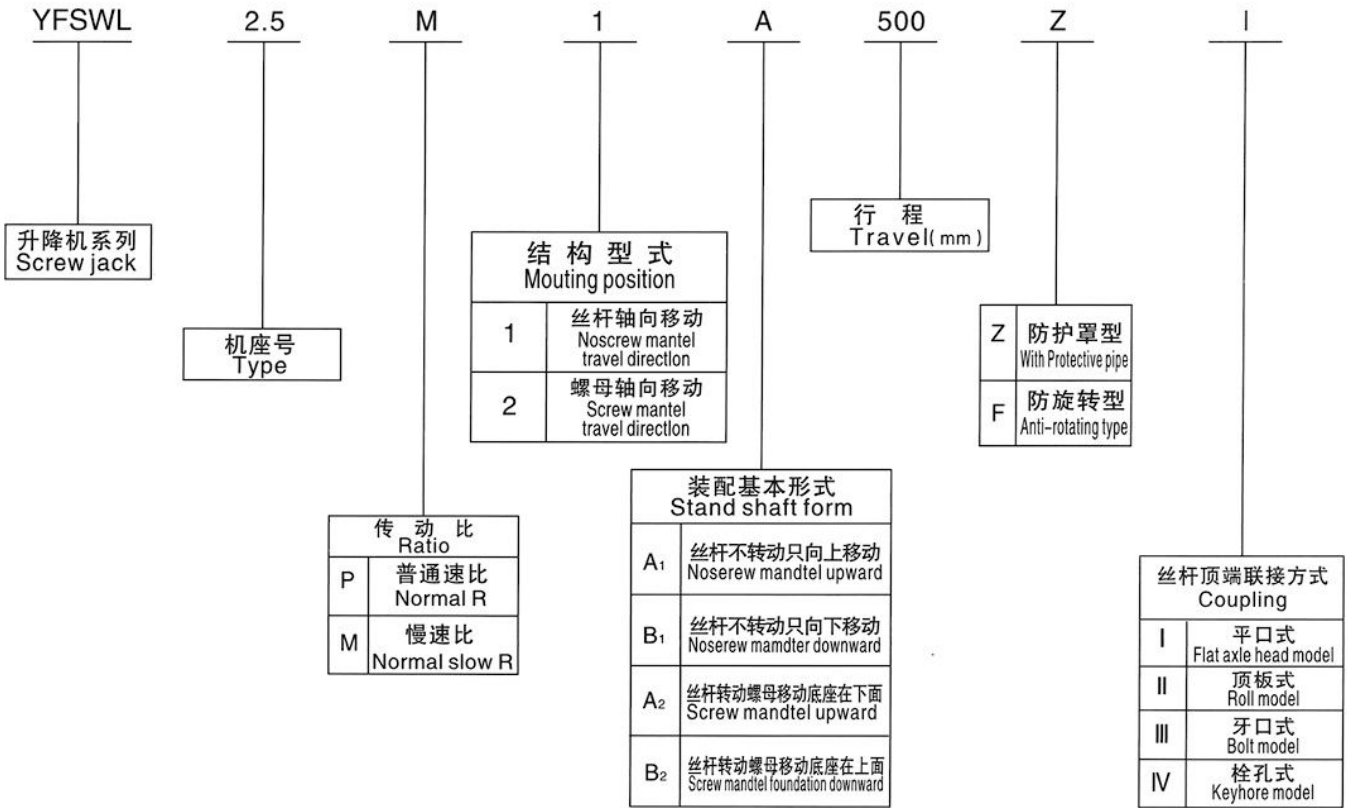

1型结构型式
mounting position 1

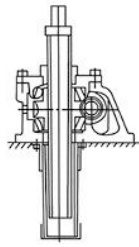

1A

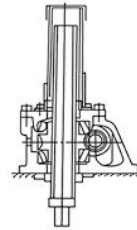

1B

2型结构型式
mounting position 2

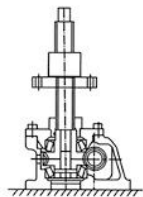

2A

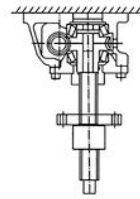

2B

升降机主要性能参数表 Fluctuating been advantaged table

型号 Model	YFSWL1	YFSWL2.5	YFSWL5	YFSWL10	YFSWL15	YFSWL20	YFSWL25	YFSWL35	YFSWL50	YFSWL75	YFSWL100	
最大起升力KN Liftmax	10	25	50	100	150	200	250	350	500	750	1000	
丝杆螺纹尺寸 Pitch of screws	Tr22x5	Tr30x8	T42x8	T58x12	T58x12	T65x12	T90x16	T110x16	T120x16	T130x18	T150x24	
丝杆底径d3 Outer diameter of screw d3	16.5	21	33	45	45	52	72	92	102	110	124	
丝杆螺距L1 Pitch of screw L1	5	8	8	12	12	12	16	16	16	18	24	
最大拉力 KN Lift load	10	25	50	100	150	200	250	350	500	750	1000	
蜗轮副 传动比 Worm wheel Ratio i	P	3/11	1/8	1/6.4	1/8.3	1/8.3	1/8	3/31	3/32	3/32	3/38	3/46
	M	1/22	1/25	1/25	1/24	1/24	1/24	1/27	1/29	1/38	1/33	1/40
蜗杆每 转行程 Worm Travel	P	1.36	1	1.25	1.44	1.44	1.50	1.55	1.5	1.5	1.421	1.565
	M	0.227	0.32	0.32	0.5	0.5	0.5	0.59	0.55	0.474	0.485	0.5
满载时蜗 杆扭矩N.m Worntorque	P	6.2	18	39.5	119	179	240	366	464	856	1380.5	2040.9
	M	2.9	8.86	19.8	60	90	122	217	253	453.3	761.3	1278.3
效率% Efficiency	P	21	22	23	20.5	20.5	19.5	16	18	15	13	13
	M	12	11	11.5	13	13	12.8	9	11	10	8	8
空载扭矩 To(N·m) No-load torque To(N·m)	0.29	0.02	1.4	2.0	2.6	3.9	6.8	12.3	19.6	29.4	39.2	
不加行程的重量kg Not in cluding Travel weight	5.5	7.7	18	27	33	42	75	92.2	248	370	748	
功率kW Power	$P = T \times n / 9550$ [T:扭矩(N.m) n:转速(r/min)] $P = T \times n / 9550$ [T:torque(N.m) n:speed(r/min)]											
润滑剂 Lubrication	合成钙纳基润滑脂 ZGN-1或 ZGN-2 (-20℃~100℃) Calcium gease ZGN-1或 ZGN-2 (-20℃~100℃)											
最大行程 Travelmax	300	400	770	1000	800	980	1500	1500	2000	2000	2000	
拉力负荷行程可加大												

注意事项:

- 1) 选择升降机时不论静载、动载、冲击载荷均不得超过其允许承受的最大载荷,根据安全系数、使用行程、校对丝杆的稳定性选择具有充分容量的升降机;
- 2) 一定要注意丝杆轴转速与承受的载荷进行搭配,对于升降机的容许最大载荷、容许外加负载、容许丝杆轴的旋转速度等项目进行校验,如果超过产品的数据将会造成升降机设备整体的重大损伤;
- 3) 升降机在工作时其减速部表面温度应控制在-15℃~80℃的范围以内,确保活动螺母表面温度也在上述范围以内;
- 4) 输入轴容许转速为1500r/min,输入轴不得超过此转速;
- 5) YFSWL不可连续运转:
单台升降机的负荷时间率(%ED)以30分为单位计算, YFSWL(梯形丝杆类型)的负荷时间内不得超过20%ED。
负荷时间率%ED=
$$\frac{\text{1动作周期的工作时间}}{\text{1动作周期的工作时间}+\text{1动作周期的停歇时间}} \times 100\%$$
- 6) 对于在同一轴线上联接数台升降机时,请务必对输入轴强度进行校核,使每台升降机所承担的扭矩都应在其容许输入轴扭矩以内;
- 7) 驱动源的起动力矩应确保在使用扭矩的200%以上;
- 8) 在零摄氏度以下工作时因受润滑油粘性变化的影响使得整机效率下降,所以必须选有充足的驱动源;
- 9) YFSWL型理论上具有自锁功能,但工作在振动冲击较大的场合时会导致自锁功能失灵,因此须外加一制动装置或选择带有制动的驱动源。
- 10) 升降机使用的环境如下:

使用场所	Working Location	室内无雨水侵入的场所	Indoor location without rainwater
周围空气	Ambient Air	灰尘为一般工厂状态	Normal
环境温度	Ambient Temperature	-15℃~10℃	
相对湿度	Relative Humidity	85%以下	Less than 85%

- 11) 当升降机工作在多灰尘的场所中时请务必选择防尘罩伸缩套附件来保护丝杆,在室外使用时请务必考虑使用罩壳等装置,使机器不直接受到风吹雨打;
- 12) 在升降机工作时,不得进行人为的强行停机,否则将使升降机受到严重破损;

Note:

- 1) Select a Jack with sufficient capacity according to safety factor, service journey and stability. And stationary load, dynamic load and shock load must be lower than permissible maximum load.
- 2) Please note that rotation speed of screw must match load, permissible maximum load, permissible maximum outer load, and permissible rotation speed of screw must be verified. If these figures exceed that of Products, jacks will be damaged greatly.
- 3) The surface temperature will be limited in -15° ~80° when jack working to ensure the temperature of traveling nuts in -15° ~80° .
- 4) Maximum input speed is 1500r/min.
- 5) YFSWL suitable for continuous operation:
Jack Duty(%ED)
YFSWL duty(%ED) cannot exceed 20%ED,
Duty %ED=
$$\frac{\text{jack operating time(lift\&lower cycle)}}{\text{Elapsed cycle time}} \times 100\%$$
- 6) When several Jacks are connected on the same axial line, the loaded torque with each Jack must be verified and limited within permissible input torque.
- 7) Starting torque must be 200% of service torque.
- 8) At below 0° ambient temperature, changed adhesion of lubrication will lower Jack's efficiency so that sufficient drive is necessary.
- 9) YFSWL has self-lock function, but an Extra braking device or drive source with braking device is necessary to be equipped because self-lock will be of mal-function when Jack is loaded a heavy shock.
- 10) Jack's operating conditions:

- 11) When working in dusty space, Jack must be equipped with elastic dust-hook on screw; in open air, shield must be equipped to prevent exposure to wind and rain.
- 12) When working, Jack cannot be forced to stop, or it will be damaged seriously.

选型方法:

升降机型号的确定:
 计算总机的当量载荷 W_s (N)
 $W_s = \text{最大载荷 } W_{max} \times \text{使用系数 } f_1$ (N)
 被驱动设备系数 (f_1) 表:

How to select type:

Determine Jack's type:
 Calculate total equivalent load W_s (N):
 $W_s = W_{max} \times f_1$
 Service factor for driven machine (f_1):

载荷性质 Load character	使用举例 Example	被驱动设备系数 Factor for driven machine (f_1)
无冲击载荷, 负荷惯性小 shockless load & small inertia load	开关、阀门传送带切换装置 Switch, valve transmission belt swithing device	1.0~1.3
轻微冲击载荷, 负荷惯性中等 moderate shock & moderate inertia	各种移动装置; 升降用各种升降机 All kinds of moving devices, all kinds of elevators	1.3~1.5
大冲击振动载荷, 负荷惯性大 heavy shock & large inertia	用台车搬运东西; 保持压延滚轮的位置 Carrying something by trolley; to keep the position of idling gear	1.5~3.0

计算单台升降机的当量载荷 W

$$W = \frac{W_s}{\text{联动台数} \times \text{联动系数 } f_d}$$

Calculate equivalent load of single Jack,

$$W = \frac{W_s}{\text{Number} \times \text{Linkage factor } (f_d)}$$

联动系数 Linkage factor (f_d):

联动台数 Number of linkage jack	1	2	3	4	5~8
联动系数 Linkage factor	1	0.95	0.9	0.85	0.8

确定升降机型号:

充分考虑载重, 速度, 行程, 效率, 驱动源后暂时选定型号
 根据使用行程、环境条件、输出顶端的联接方式, 确定升降机的整体型号。

Temporarily determine Jack type:

Temporarily determine Jack type after taking full consideration of load, speed, journey, efficiency and drive source.
 Determine JW type according to service journey, ambient conditions, connection mode of end-fittings.

输入功率校核:

负载所需输入功率与许容量最大输入功率相比较
 如果超过请提高型号或降低丝杆轴转速再计算。

Verify input power

If required input power under load exceeds permissible maximum input power, please select larger type or lower the speed of screw rotation.

负载所需输入功率计算 Calculation of required input power under load:

所需输入轴转速 Required rotation speed of input shaft	N_1 (r/min)	$n_1 = \frac{V}{L} \times i$
所需输入轴扭矩 Required torque of input shaft	T_1 (N·m)	$T_1 = \frac{W \times L_1}{2\pi \times i \times \eta} + T_0$
所需输入功率 Required input power	P_1 (kW)	$P_1 = \frac{T_1 \times n_1}{9550}$

V : 升降机丝杆轴(活动螺母)升降速度 mm/min L : 丝杆螺距(mm)
 i : 减速比 W : 单台升降机当量无荷(N) π : 圆周率
 η : 升降机的综合效率 T_0 : 空载扭矩(Nm)
 (L 、 i 、 η 、 T_0 参照性能参数表)

V : linear speed of screw mm/min L : Pitch of screw(m)
 i : ratio W : equivalent load of single jack π : pi
 η : Integrated efficiency T_0 : No-load torque(Nm)
 (L 、 i 、 η 、 T_0 refer to basic parameter table)

丝杆稳定性校核

当丝杆承受轴向压缩载荷时, 请对其进行稳定性校核, 如超过其临界载荷值请提高型号后再计算。

Verify the stability of screw:

Please verify the stability of screw under axial load, larger type should be used when load exceed the critical load,

升降机丝杆临界稳定载荷通过以下公式计算:

The formula to calculate the critical load as follows:

$PCR = f_m \times \left(\frac{d_3^2}{L a^3} \right)$	确保 ensure	$PCR > W \times SF$ ($SF=4$)
---	--------------	--------------------------------

PCR : 临界载荷(N)
 d_3 : 丝杆底径 mm(参照性能参数表)
 f_m : 支撑系数
 $L a$: 作用点间距离, mm
 W : 单台升降机当量载荷(N)
 SF : 安全系数(一般 $SF=4$)

PCR : Critical load(N)
 d_3 : small diameter of screw end (mm)(refer to basic parameter table)
 f_m : support factor
 $L a$: distance between load-supporting point and mounting point as drawing.
 W : equivalent load of single Jack(N)
 SF : safety factor ($SF=as usual$)

丝杆轴稳定性校核时， L_a (L_a 值计算根据各型号尺寸) 与 f_m (支撑系数) 选取如下：

Verifying the stability of screw, the values of L_a and f_m as follows:

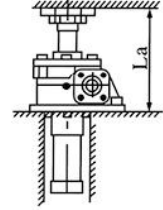
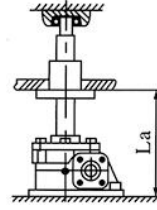
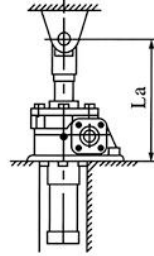
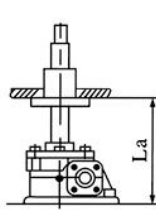
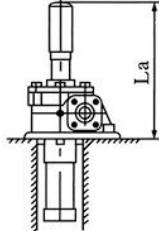
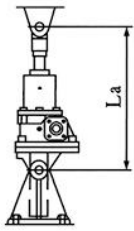

两端支撑 $f_m=10 \times 10^4$
support at both ends $f_m=10 \times 10^4$

底座固定轴端自由 $f_m=2.5 \times 10^4$
Foot-mounted & movable shaft end $f_m=2.5 \times 10^4$

底座固定轴端支撑或固定 $f_m=2.5 \times 10^4$
Foot-mounted & shaft end supporting or fixed $f_m=2.5 \times 10^4$

临界转速校核

如为活动螺母选型时，请务必将丝杆轴转速控制在临界转速以下，若超出临界转速，请提高型号再计算。

Verifying critical rotation speed:

Using traveling nut, the rotation speed of screw must be lower than critical speed, if no, please select larger type and calculate again.

$$n_c = \frac{96 \times f_n \times d_3 \times 10^6}{L_b^2}$$

$$n_s = \frac{n_1}{i}$$

n_c : 临界转速 r/min

d : 丝杆底径 mm (参照性能参数表)

f_n : 长度系数

L_b : 支撑间距离 mm

n_s : 丝杆转速 r/min

n_1 : 输入速度 r/min

i : 减速比

n_c : Permissible rotation speed of screw

n_s : Rotational speed of screw

d : Small diameter of screw (refer to basic parameter table)

n_1 : Rotational speed of input shaft

f_n : Length factor

i : ratio

L_b : Distance between both supporting face

丝杆轴转速样难时， L_b (L_b 值计算根据各型号尺寸) 与 f_n (长度系数) 选取如下：

Verifying the rotation speed of screw, the values of L_b and f_n as follows:

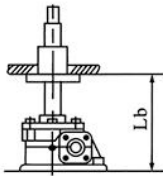

轴端自由 $f_n=0.36$
Movable shaft end $f_n=0.36$

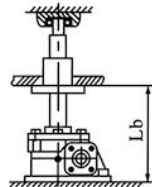

轴端支撑 $f_n=1.56$
Shaft end supporting $f_n=1.56$

请确保: $n_c > n_s$

Ensure: $n_c > n_s$

计算举例: YFSWL 200在输入转速为1200r/min, 轴端支撑下运转, 根据外形尺寸与传动能力表查得:
 $d_3=72$ $L_b=1437$

Example for calculation:
Take YFSWL as example, $n_1=1200$ r/min, connecting mode of top-end: I, we can know $d_3=72$, $L_b=1437$ referring to dimension and transmission capacity table.

$$n_s = \frac{n_1}{i} = \frac{1200}{8} = 150 \text{ r/min}$$

$$n_c = \frac{96 \times f_n \times d_3 \times 10^6}{L_b^2} = \frac{96 \times 1.56 \times 72 \times 10^6}{(1437)^2} = 5222 \text{ r/min}$$

$$n_c = 5222 \text{ r/min} > n_s = 150 \text{ r/min} \dots \dots \text{OK.}$$

当有横向载荷时，请外加导向器。

When there is radial load, please add guiding denice.

YFSWL许用横向载荷 Permitted radial load Fr(N):

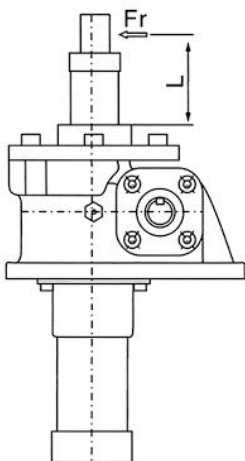

Fr(N) L(mm)	Type	010	025	050	100	150	200	300	500	750	1000
100		318	570	2500	4010	4610	8210	38200	85300	73500	186200
200		159	290	1250	2010	2300	4110	23000	50400	56800	145000
300		106	190	830	1340	1540	2740	15300	33600	46100	104700
400		76	140	620	1000	1150	2050	11400	25200	39300	78500
500		64	110	500	800	920	1640	9100	20200	33900	62800
600		53	100	420	670	770	1370	7600	16800	29900	62300
700		51	90	360	570	660	1170	6500	14400	26700	44800
800		48	90	310	500	580	1030	5700	12600	24100	39200
900		45	90	280	450	510	910	5000	11200	22000	34800
1000		42	90	250	400	460	820	4500	10100	20200	31300

YFSWL超过许用横向载荷时，请外加导向装置，举例如下：

When operating radial load exceeds critical radial load, please add guiding device, for example:

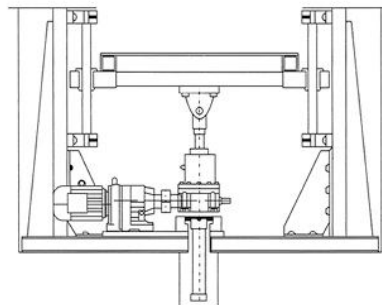
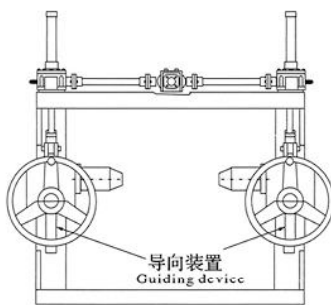

当升降机传动配置为串联时（即同一轴线配置了两个或以上数量的升降机）如图须对各升降机输入轴端进行强度校核；

Please verify input torque of each Jack when several Jack are connected on the same input axial line as the following:

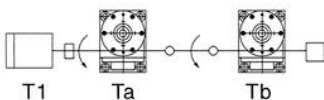

Ta: 为升降机a的所需输入扭矩
Tb: 为升降机b的所需输入扭矩
电机必需的扭矩 $T1 = Ta + Tb <$ 升降机a的容许输入轴扭矩

Ta: Required torque of input shaft of jack a.
Tb: Required torque of input shaft of jack b.
Required torque of motor $T1 = Ta + Tb <$ Promitted input torque of jack a.

升降机选择举例：

例题：4台联动机，结构如下图所示的4台联动模式，工厂内保持常温，有少许灰尘，有横向负荷在升降机侧面设置了导向器，安装状态采用底座固定，轴端采用一固定一支撑，电源为三相380V/50HZ，使用频率为2次/小时×8小时

- 1、最大轴向载荷：88.2KN/4台
- 2、升降速度：10mm/s (600mm/min)
- 3、使用行程：260mm

Jack selection example:

Example: Four Jacks, linked as the following drawing, normal temperature, thin dust, radial load, with guiding devices on one side, foot-mounted, fixed the screw top-end, 380v/50Hz, service frequency: 2 times/hour, service time: 8 hours.

1. Maximum axial load; 88.2KN/4 Jacks
2. Linear speed: 10mm/s(600mm/min)
3. Service journey: 260mm

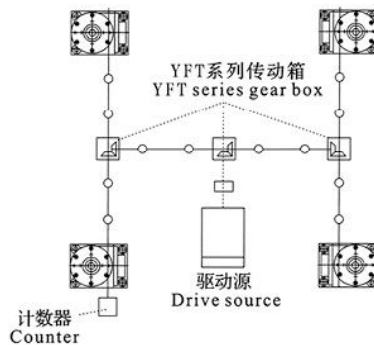

升降机型号确定：

- 1> .计算总机当量载荷 W_s (取被驱动设备系数为1.3)

$$W_s = W_{max} \cdot f_1 = 88200 \times 1.3 = 114660N$$

- 2> .计算单台当量载荷 W

$$W = \frac{114660}{4 \times 0.85} = 33724N$$

- 3> .暂定型号：

考虑速度、效率、驱动源、载重后暂定选择 YFSWL10 (参照性能参数表)

- 4> .行程校核：

使用行程为260mm，充分考虑余量后选定行程为300mm (参照YFSWL10尺寸表)

- 5> 输入功率校核：

- (1) 所需输入功率计算：

$$\textcircled{1} n_1 = \frac{V}{L_1} \times i = \frac{0.60}{0.012} \times 8.3 = 415r/min$$

$$\textcircled{2} T_1 = \frac{W \times L_1}{2\pi \times i \times \eta} + T_0$$

$$\textcircled{3} P_1 = \frac{T_1 \times n_1}{9550}$$

$$= \frac{33724 \times 0.012}{2 \times 3.14 \times 83 \times 0.205} + 1.34 = 39.2Nm$$

$$= \frac{39.2 \times 415}{9550} = 1.7kW$$

- (2) 参照性能参数表, $P_{1max} = 2.2kW > P_1 \dots \dots OK$

$$P_{max} = 119 \times (1500/8.3) / 9550 = 2.2kW$$

- 6> .丝杆稳定性校核：

因为施加压缩载荷，根据传动能力及外尺寸图得出：

$$d_3 = 45 \quad L_a = 604 + 33 = 637 \quad f_m = 20 \times 10^4 \quad SF = 4$$

$$P_{CR} = f_m \times \left(\frac{d_3}{L_a} \right)^2 = 20 \times 10^4 \times \left(\frac{45}{637} \right)^2 = 2021162N$$

$$P_F = \frac{P_{CR}}{SF} = \frac{2021162}{4} = 505290 > W = 33724 \quad \dots \dots OK$$

Determine Jack type:

- 1> Calculate total equivalent load W_s

(Factor for driven machine is 1.3)

$$W_s = W_{max} \cdot f_1 = 88200 \times 1.3 = 114660N$$

- 2> Calculate equivalent load of single jack:

- 3> Temporarily determine type,

Temporarily determine YFSWL10 according to speed, efficiency, drive and Load (refer to basic parameter table)

- 4> Verify journey:

Service journey is 260mm, determine journey should be 300 after considering surplus.

(Please refer to dimension sheet of YFSWL10).

- 5> Check input power:

- (1) Calculate required input power:

输入转向与丝杆上下运动关系如下：

The relation of input shaft veer and screw mandrel fluctuant movement as f ollows:

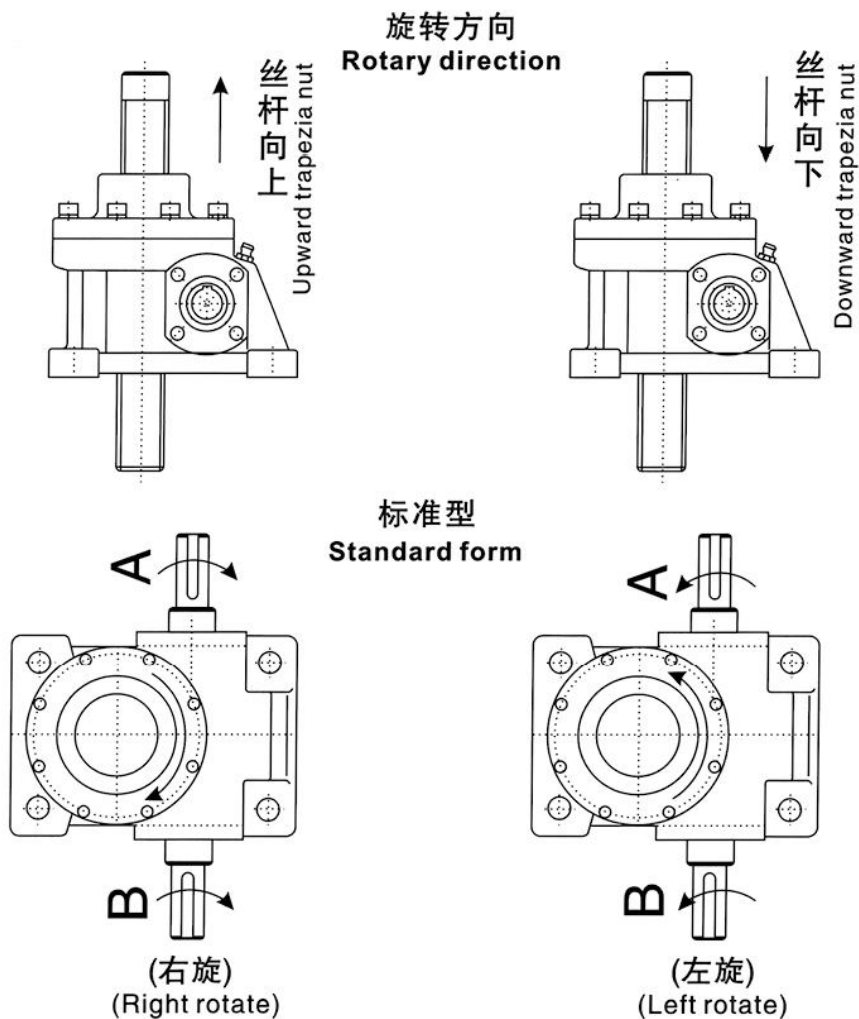

YFSWL系列蜗杆升降机结构示意图

YFSWLS tructural representation of SJ series worm screw elevators

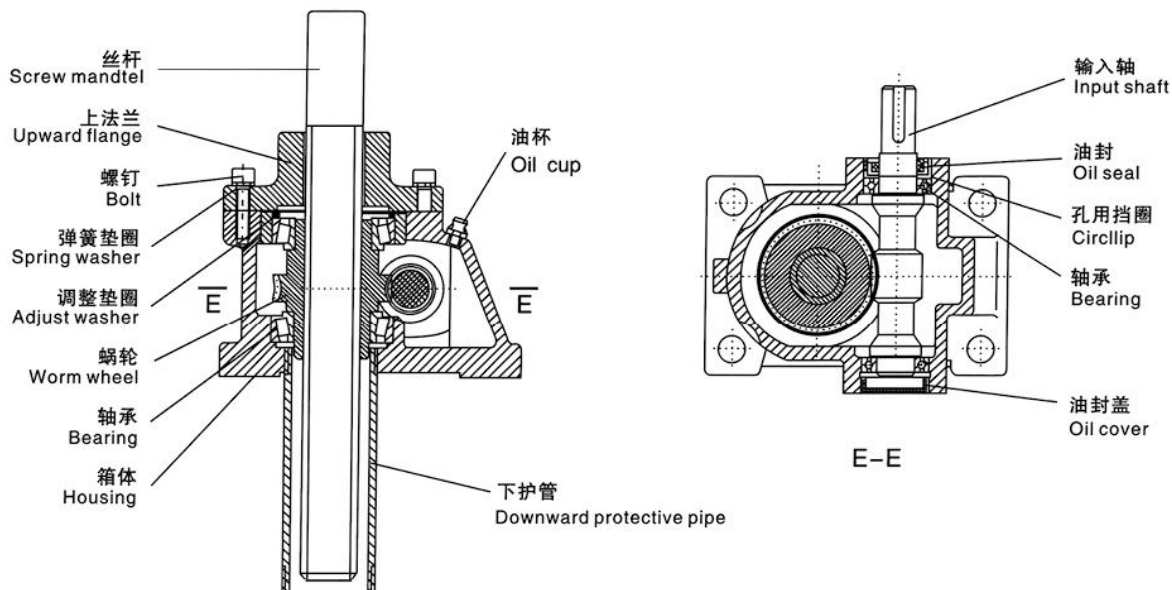

YFSWL1.0

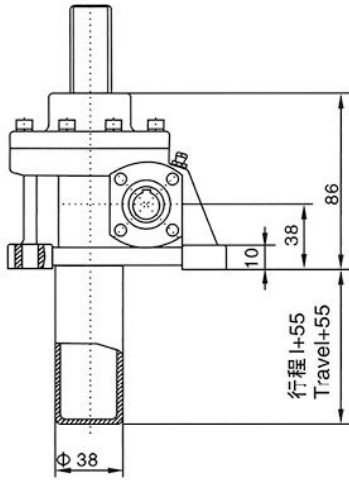

I型(平口式) / I shape (flat axle head model)

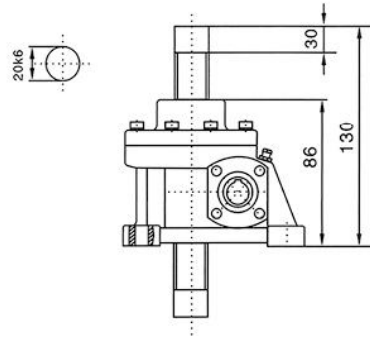

双输入/Double input shaft

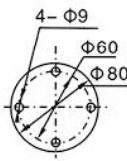
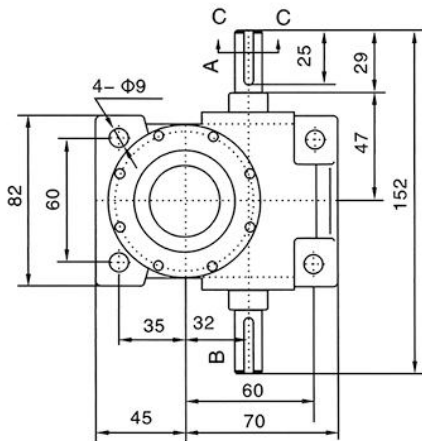

II型(顶板式) / II shape (roof model)

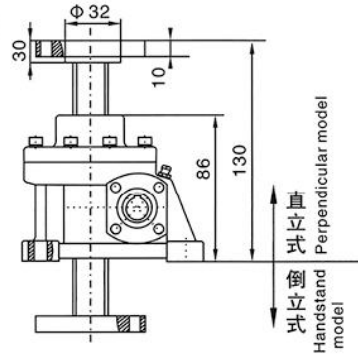

III型(牙口式) / III shape (bolt model)

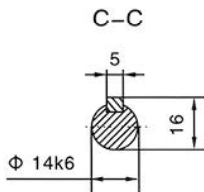
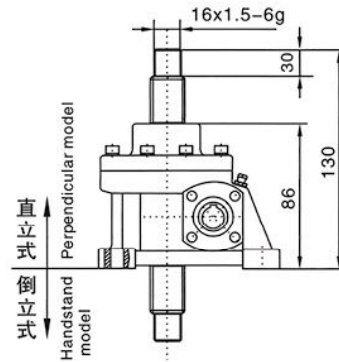

IV型(栓孔式) / IV shape (keyhole model)

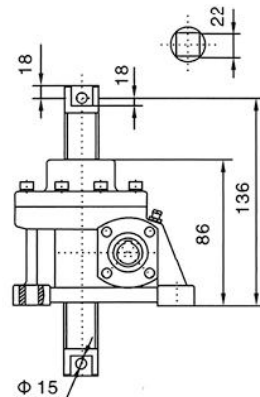
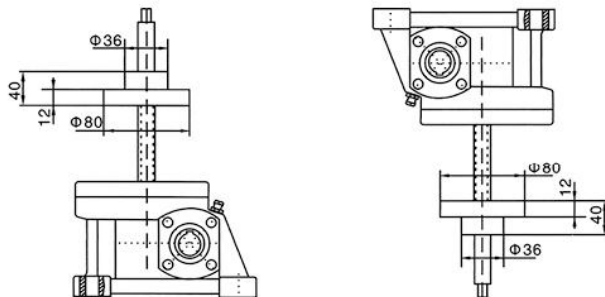

YFSWL2.5

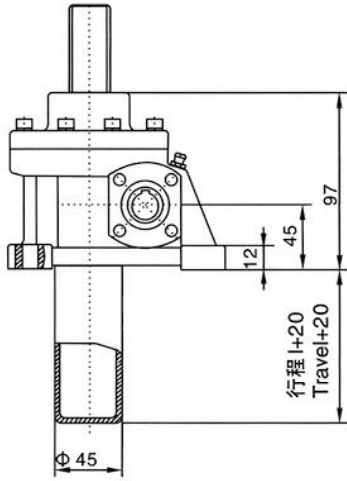

双输入/Double input shaft

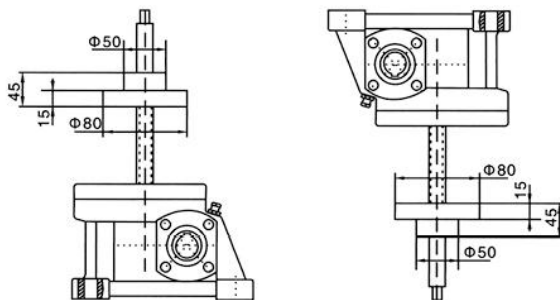
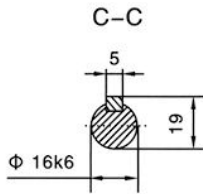
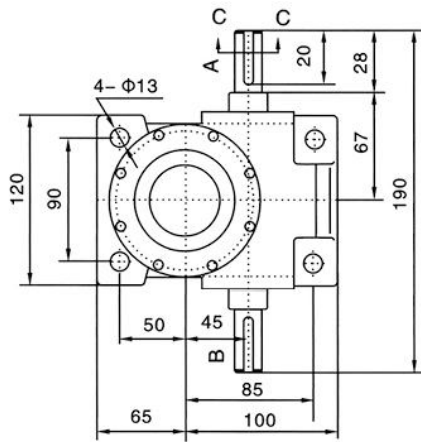

I型(平口式)/ I shape (flat axle head model)

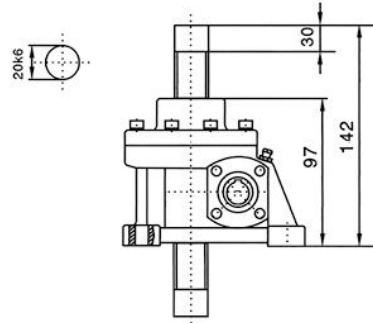

II型(顶板式)/ II shape (roof model)

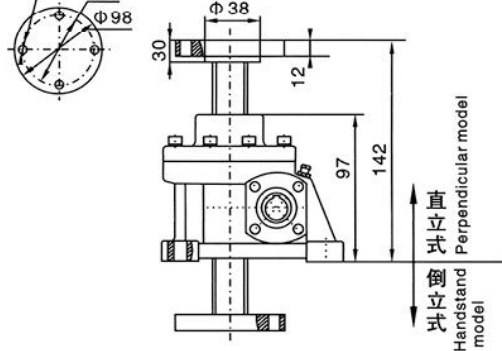

III型(牙口式)/ III shape (bolt model)

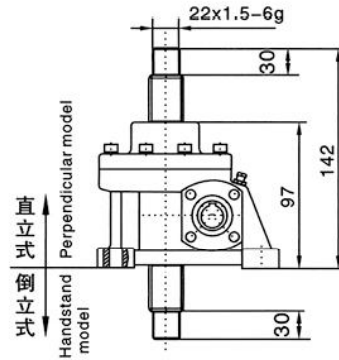

IV型(栓孔式)/ IV shape (keyhole model)

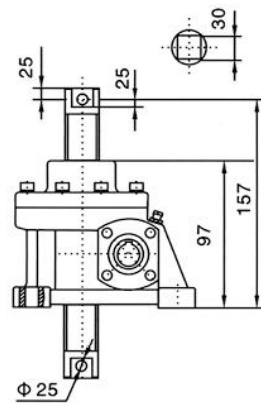

YFSWL5

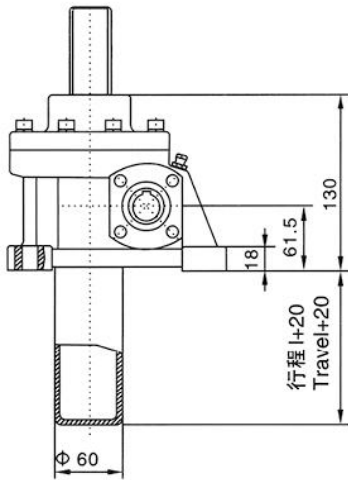

双输入
Double input shaft

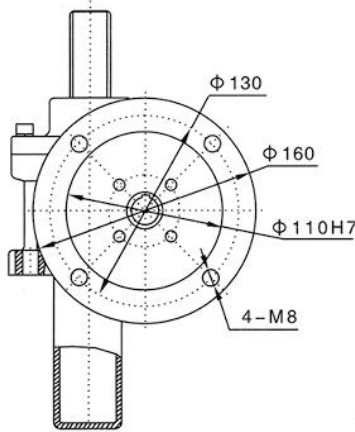

直联双输入
Direct double input shaft

I型(平口式)
I shape (flat axle head model)

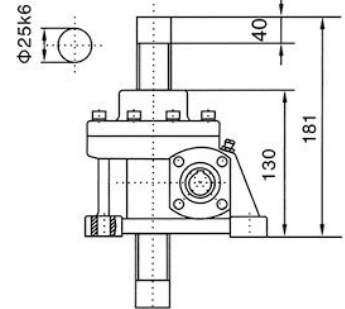

II型(顶板式)
II shape (roof model)

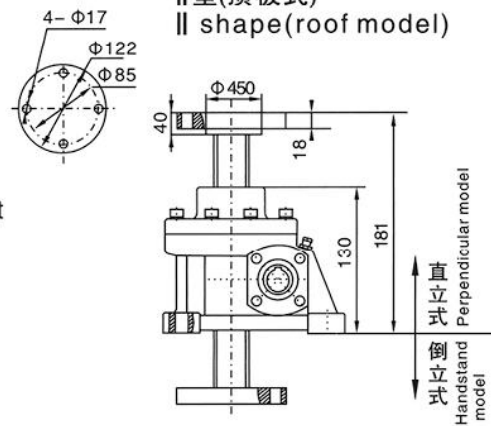

III型(牙口式)
III shape (bolt model)

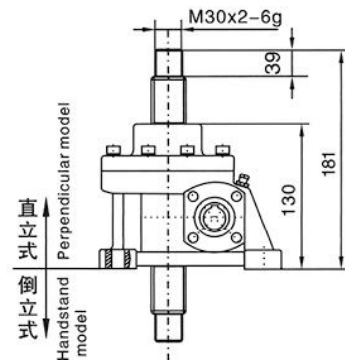

IV型(栓孔式)
IV shape (keyhole model)

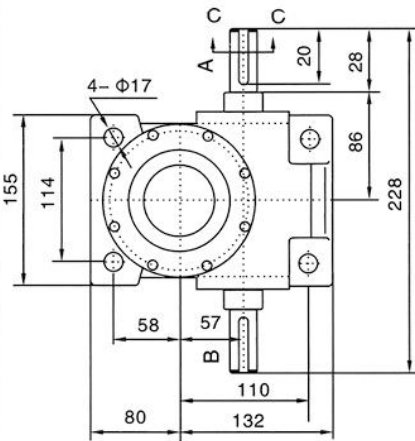
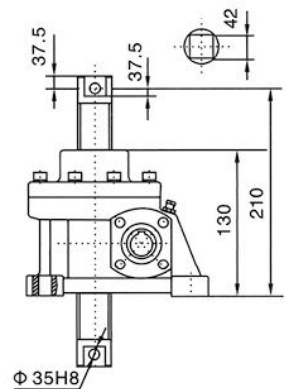

直联单输入
Direct single input shaft

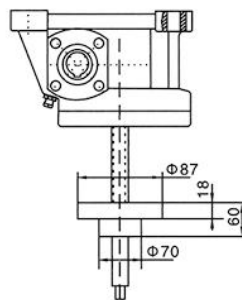
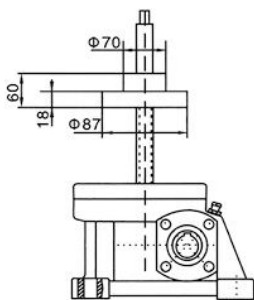
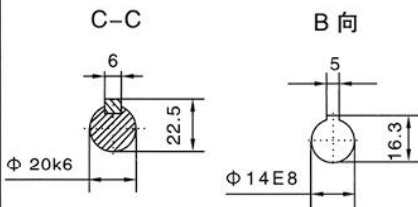
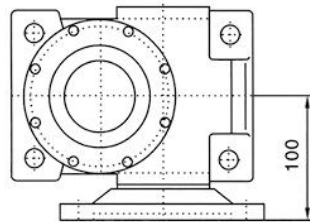
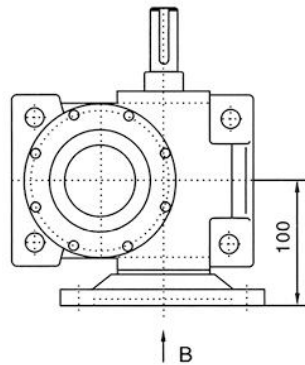

YFSWL10
YFSWL15

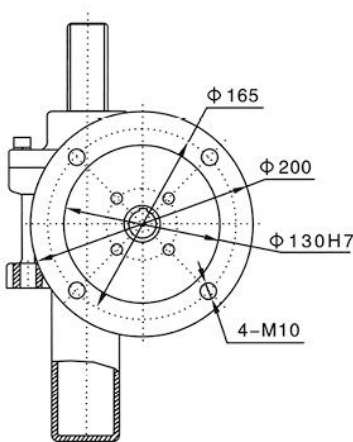
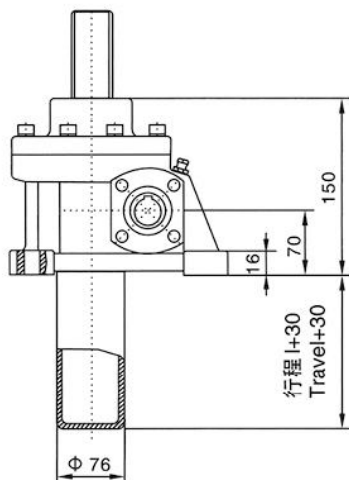

I 型(平口式)
I shape (flat axle head model)

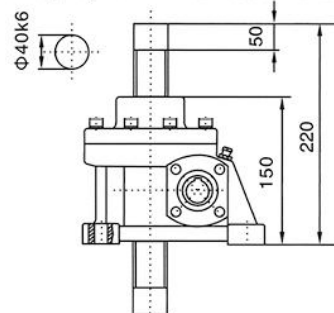

II 型(顶板式)
II shape (roof model)

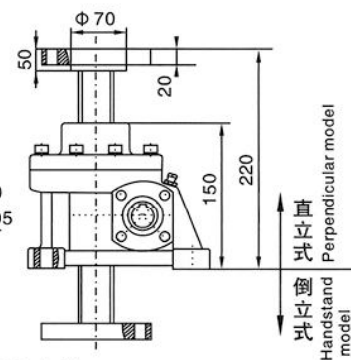

双输入
Double input shaft

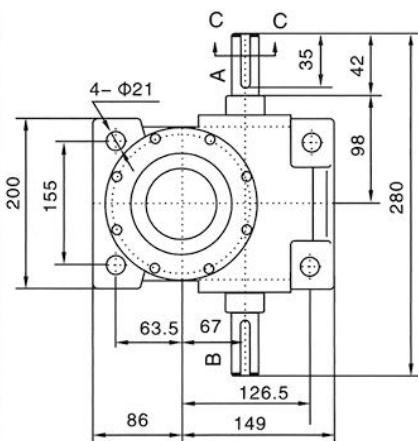

直联双输入
Direct double input shaft

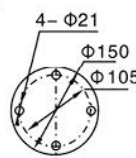
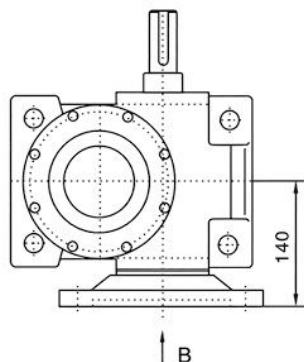

III 型(牙口式)
III shape (bolt model)

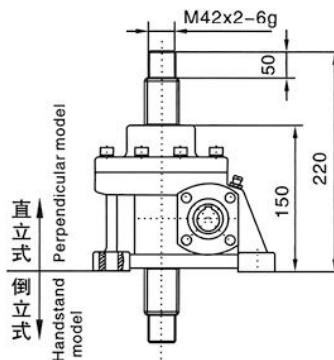

B 向

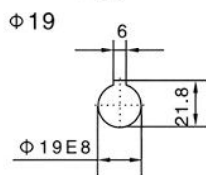

直联单输入
Direct single input shaft

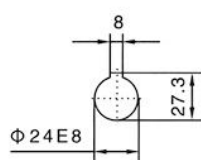
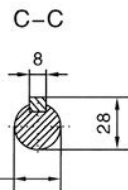
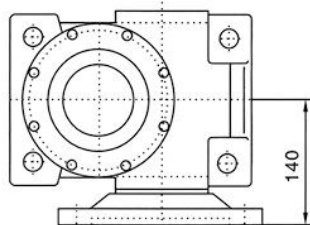

IV 型(栓孔式)
IV shape (keyhole model)

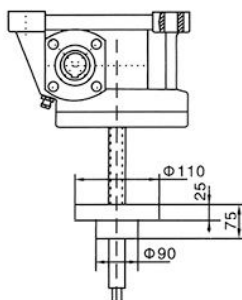
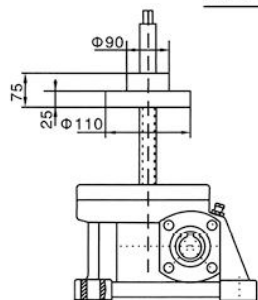
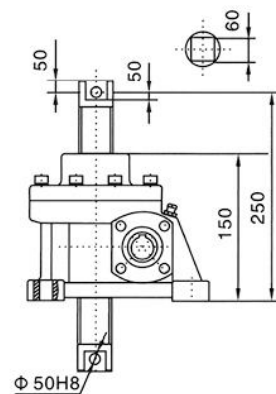

YFSWL20

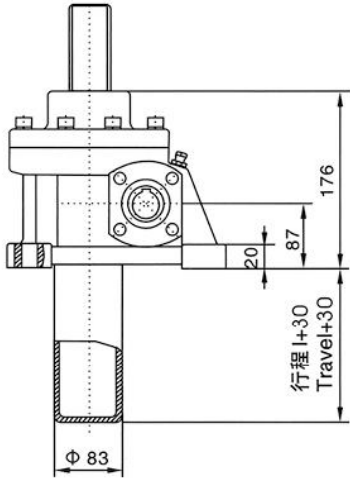

双输入
Double input shaft

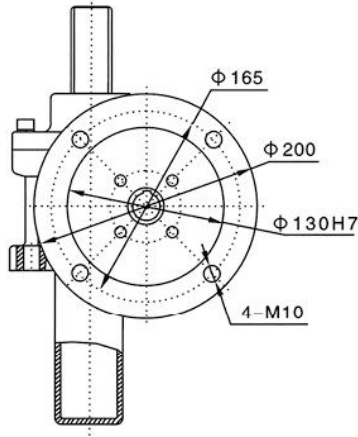

直联双输入
Direct double input shaft

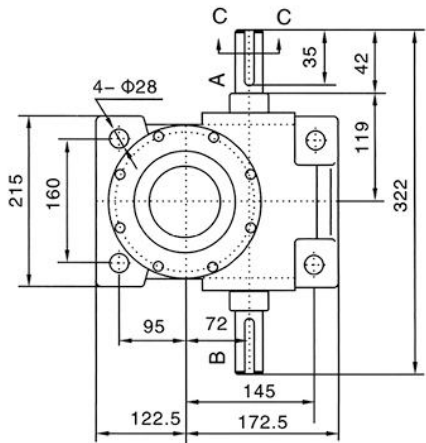

直联单输入
Direct single input shaft

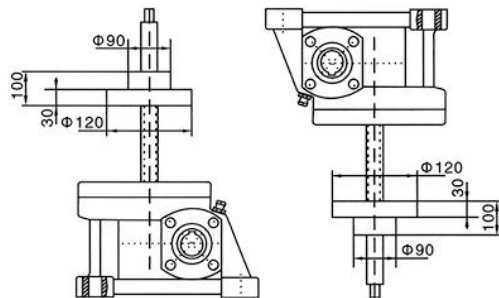
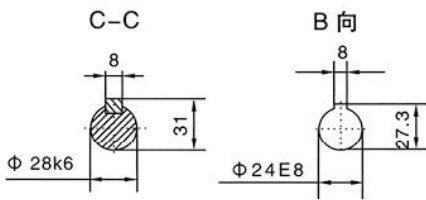

I型(平口式)
I shape (flat axle head model)

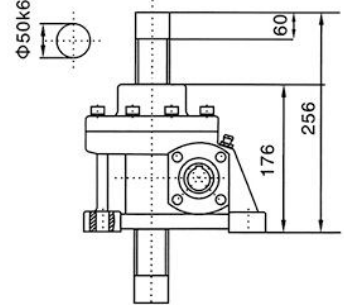

II型(顶板式)
II shape (roof model)

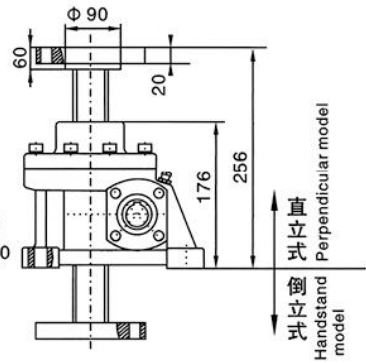

III型(牙口式)
III shape (bolt model)

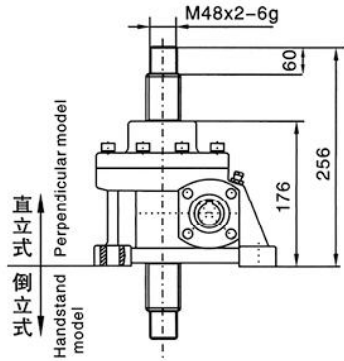

IV型(栓孔式)
IV shape (keyhole model)

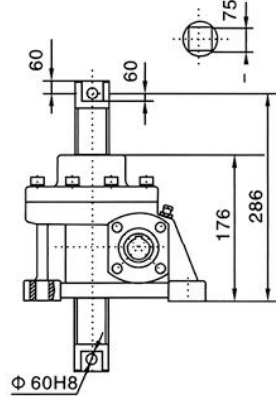

YFSWL25

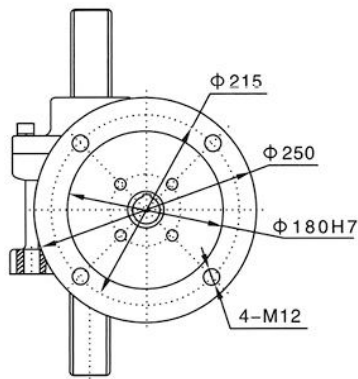
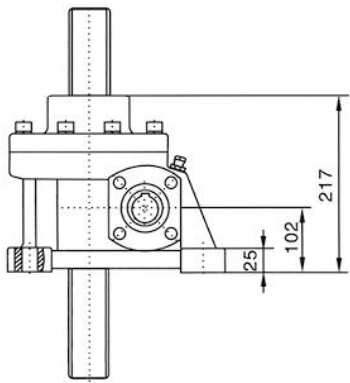

I型(平口式)
I shape (flat axle head model)

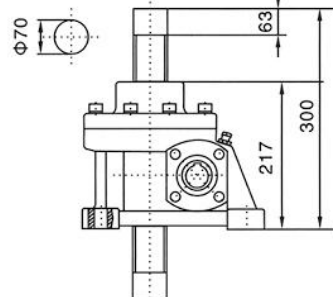

II型(顶板式)
II shape (roof model)

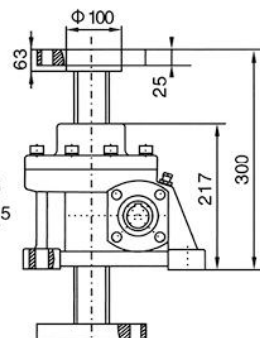

直立式
Perpendicular model
倒立式
Handstand model

III型(牙口式)
III shape (bolt model)

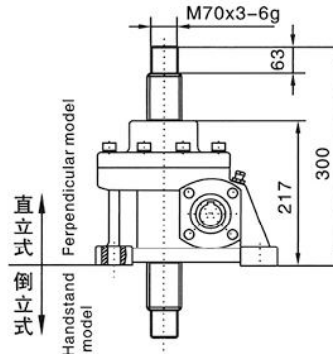

IV型(栓孔式)
IV shape (keyhole model)

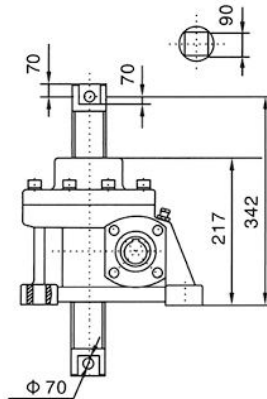

双输入
Double input shaft

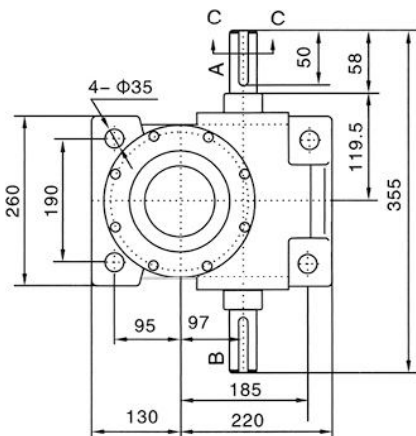

直联双输入
Direct double input shaft

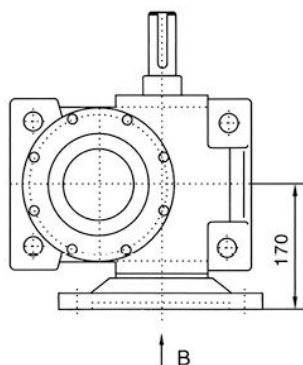

直联单输入
Direct single input shaft

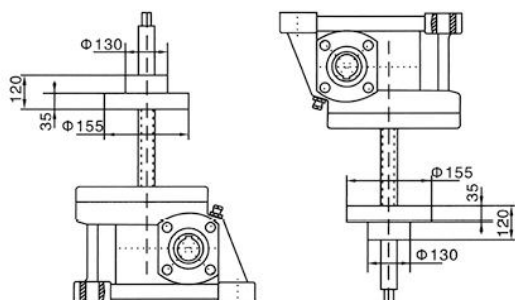
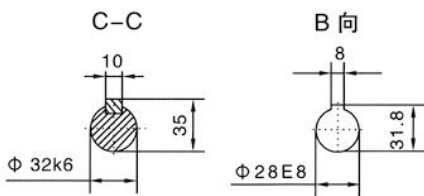
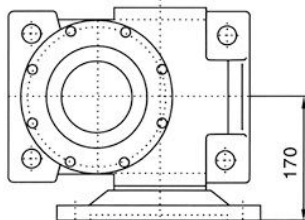

YFSWL35

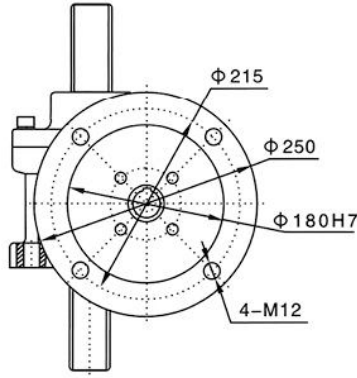
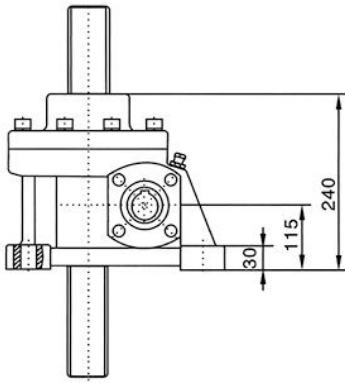

I型(平口式)
I shape (flat axle head model)

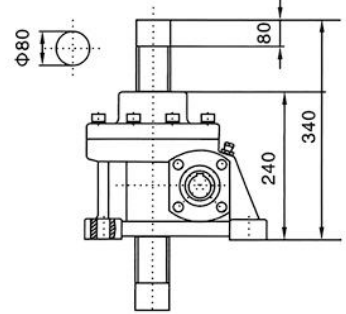

II型(顶板式)
II shape (roof model)

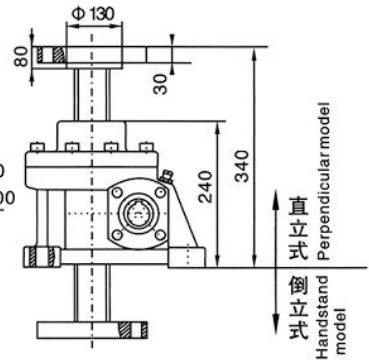

双输入
Double input shaft

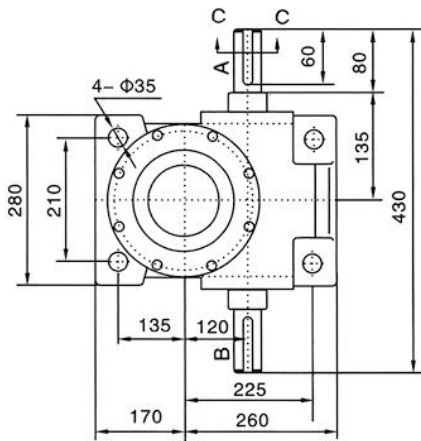

直联双输入
Direct double input shaft

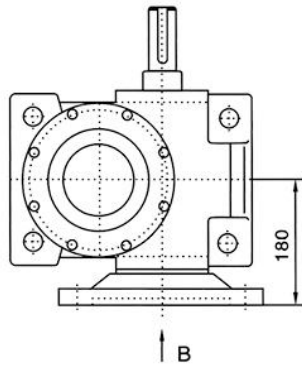

III型(牙口式)
III shape (bolt model)

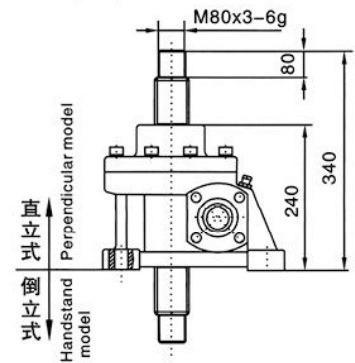

直联单输入
Direct single input shaft

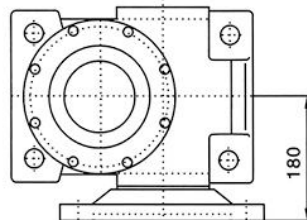

IV型(栓孔式)
IV shape (keyhole model)

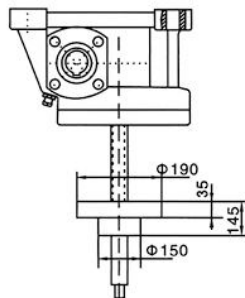
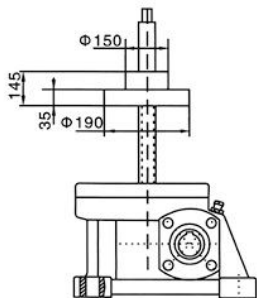
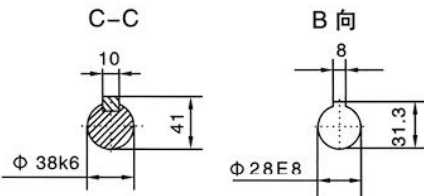
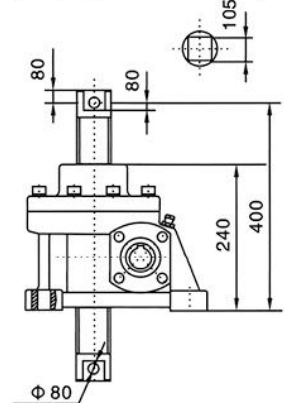

YFSWL50

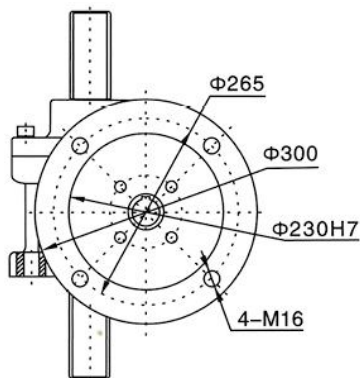
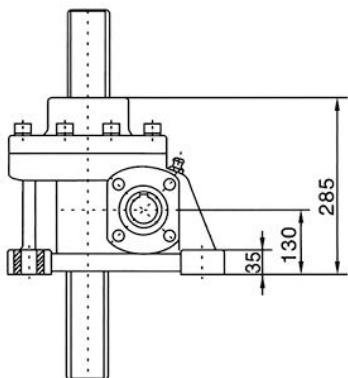

I型(平口式)
I shape (flat axle head model)

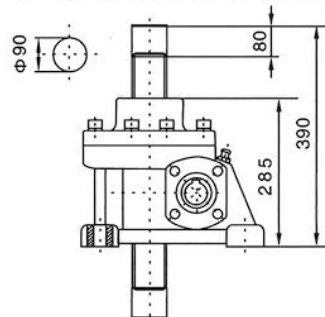

II型(顶板式)
II shape (roof model)

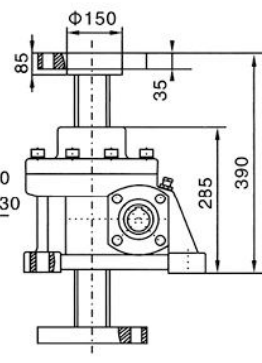

直立式
Perpendicular model
倒立式
Handstand model

双输入
Double input shaft

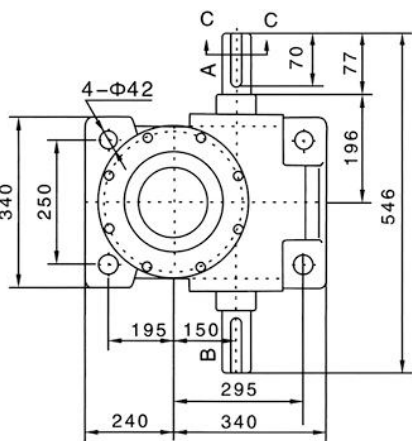

直联双输入
Direct double input shaft

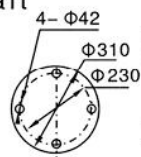
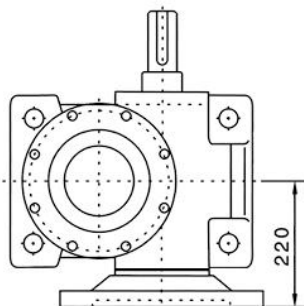

III型(牙口式)
III shape (bolt model)

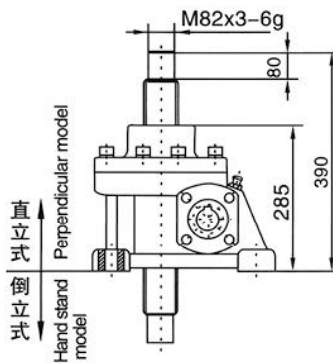

直立式
Perpendicular model
倒立式
Hand stand model

直联单输入
Direct single input shaft

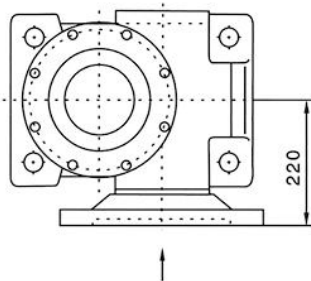

IV型(栓孔式)
IV shape (keyhole model)

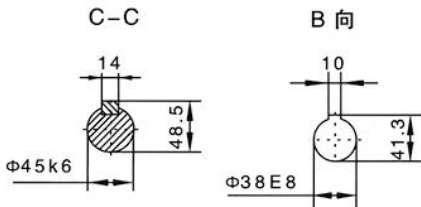
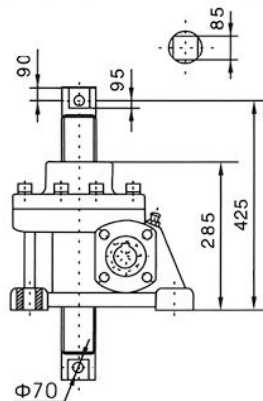

YFSWL75

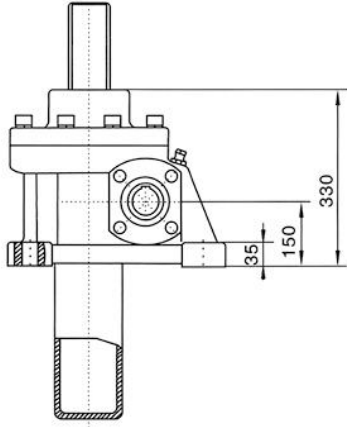

双输入
Double input shaft

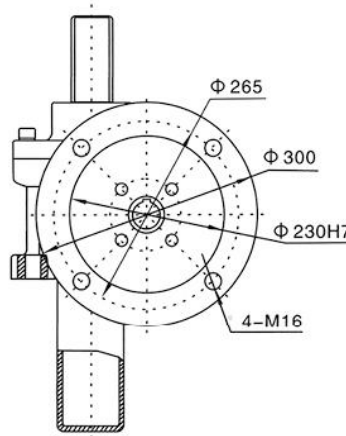
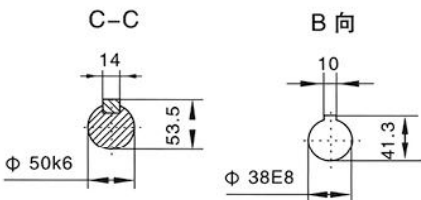
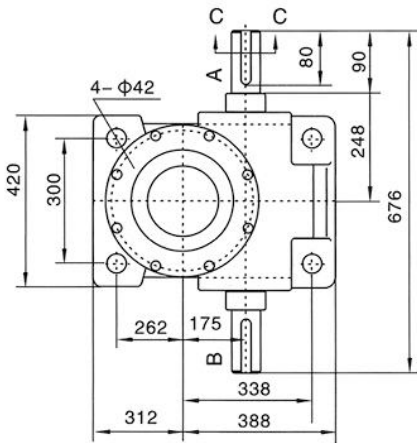

直联双输入
Direct double input shaft

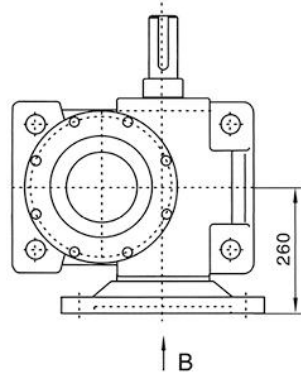

直联单输入
Direct single input shaft

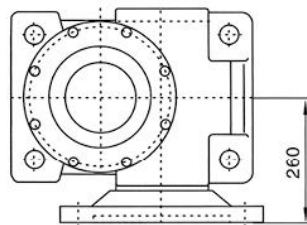

I型(平口式)
I shape (flat axle head model)

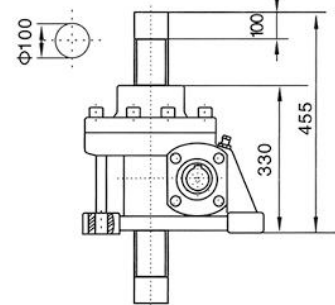

II型(顶板式)
II shape (roof model)

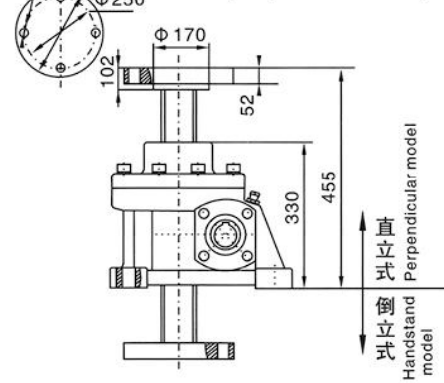

III型(牙口式)
III shape (bolt model)

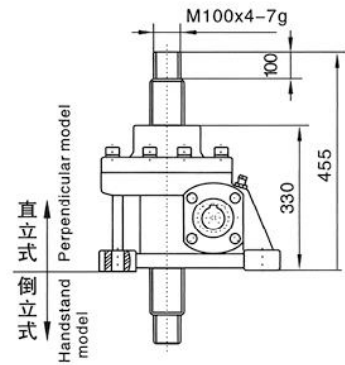

IV型(栓孔式)
IV shape (keyhole model)

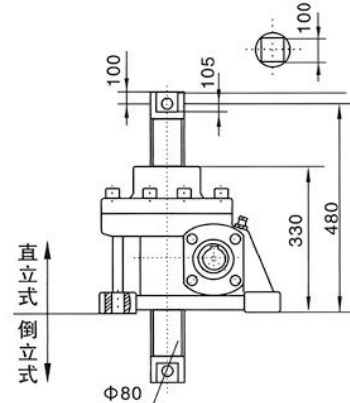

YFSWL100

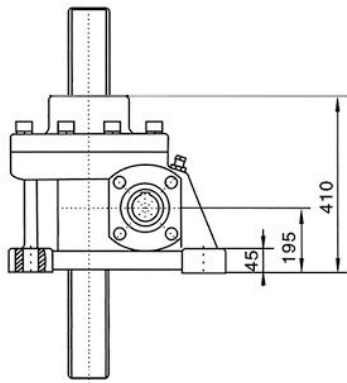

双输入
Double input shaft

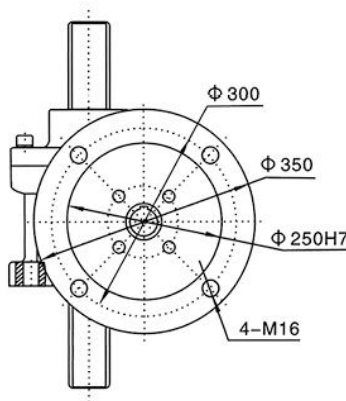
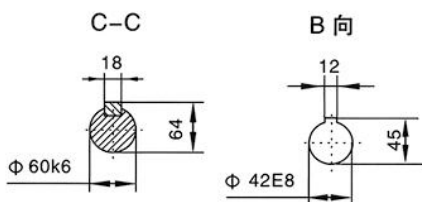
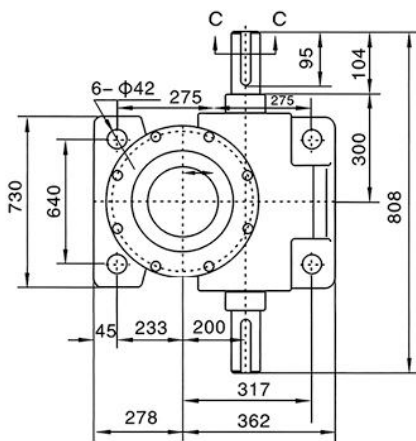

直联双输入
Direct double input shaft

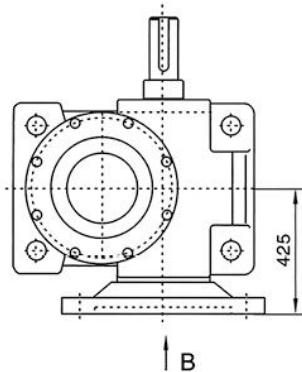

直联单输入
Direct single input shaft

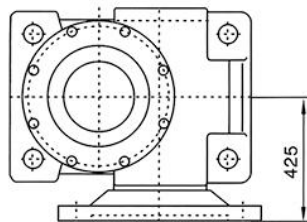

I 型(平口式)
I shape (flat axle head model)

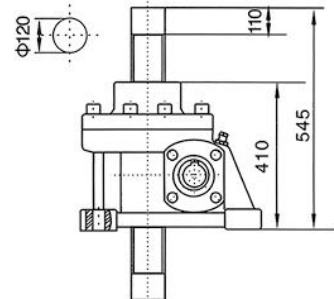

II 型(顶板式)
II shape (roof model)

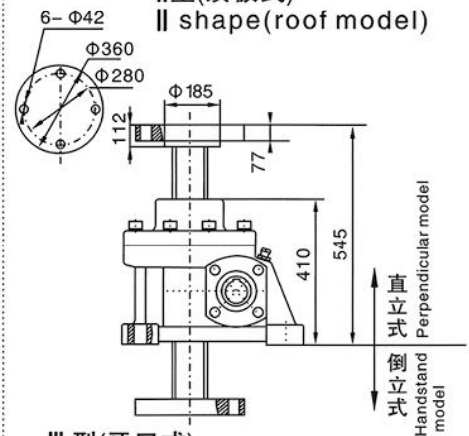

III 型(牙口式)
III shape (bolt model)

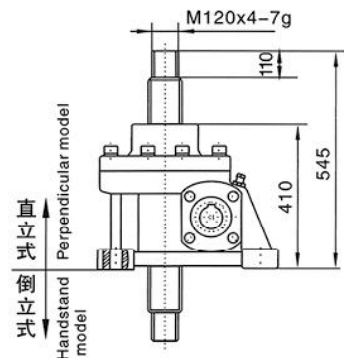

IV 型(栓孔式)
IV shape (keyhole model)

