

ZDY DBY SERIES

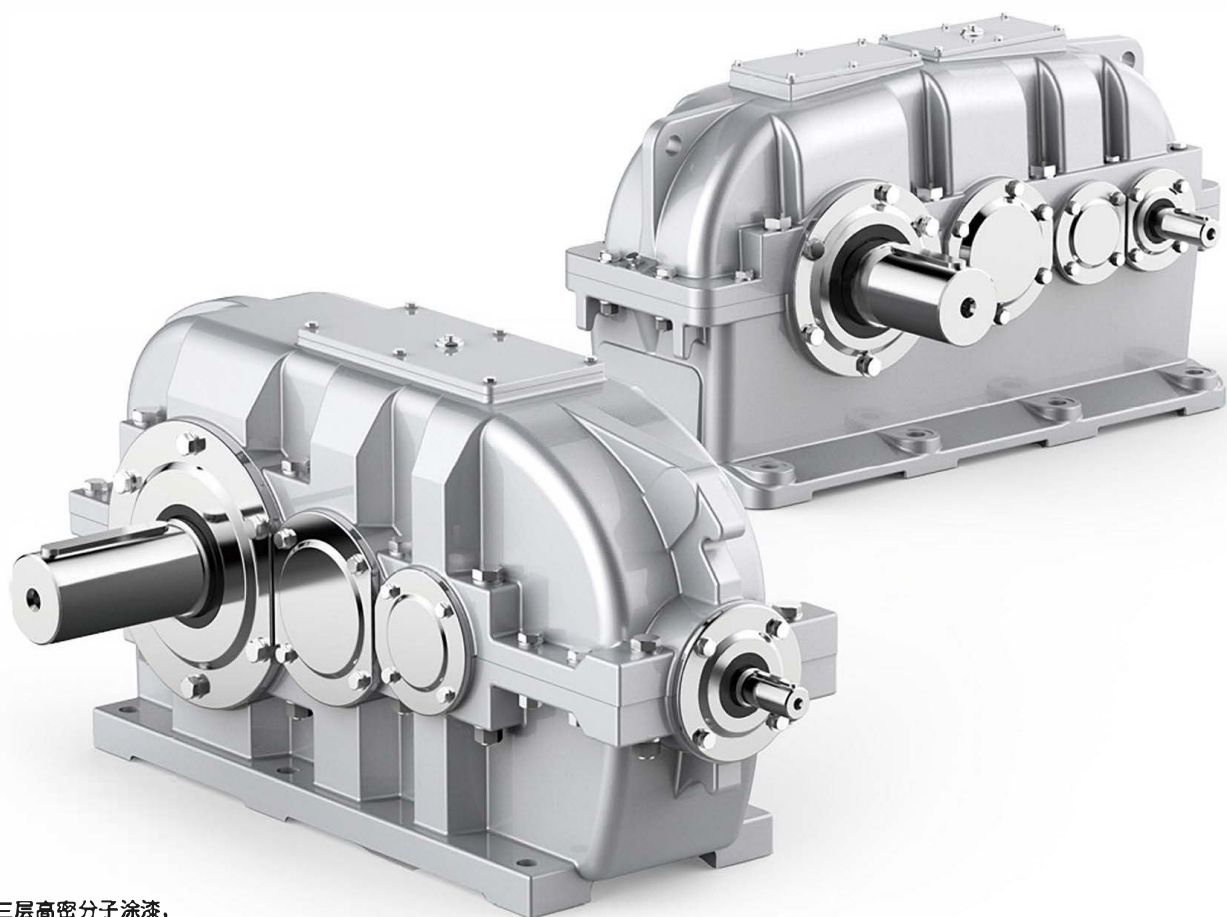

292

- ★ 三层高密分子涂漆，
隔绝灰尘更耐高温。
- ★ 高端滚珠轴承，
减少摩擦提升传动效率。
- ★ 优质合金钢精密磨齿，
提高啮合精度保证品质。

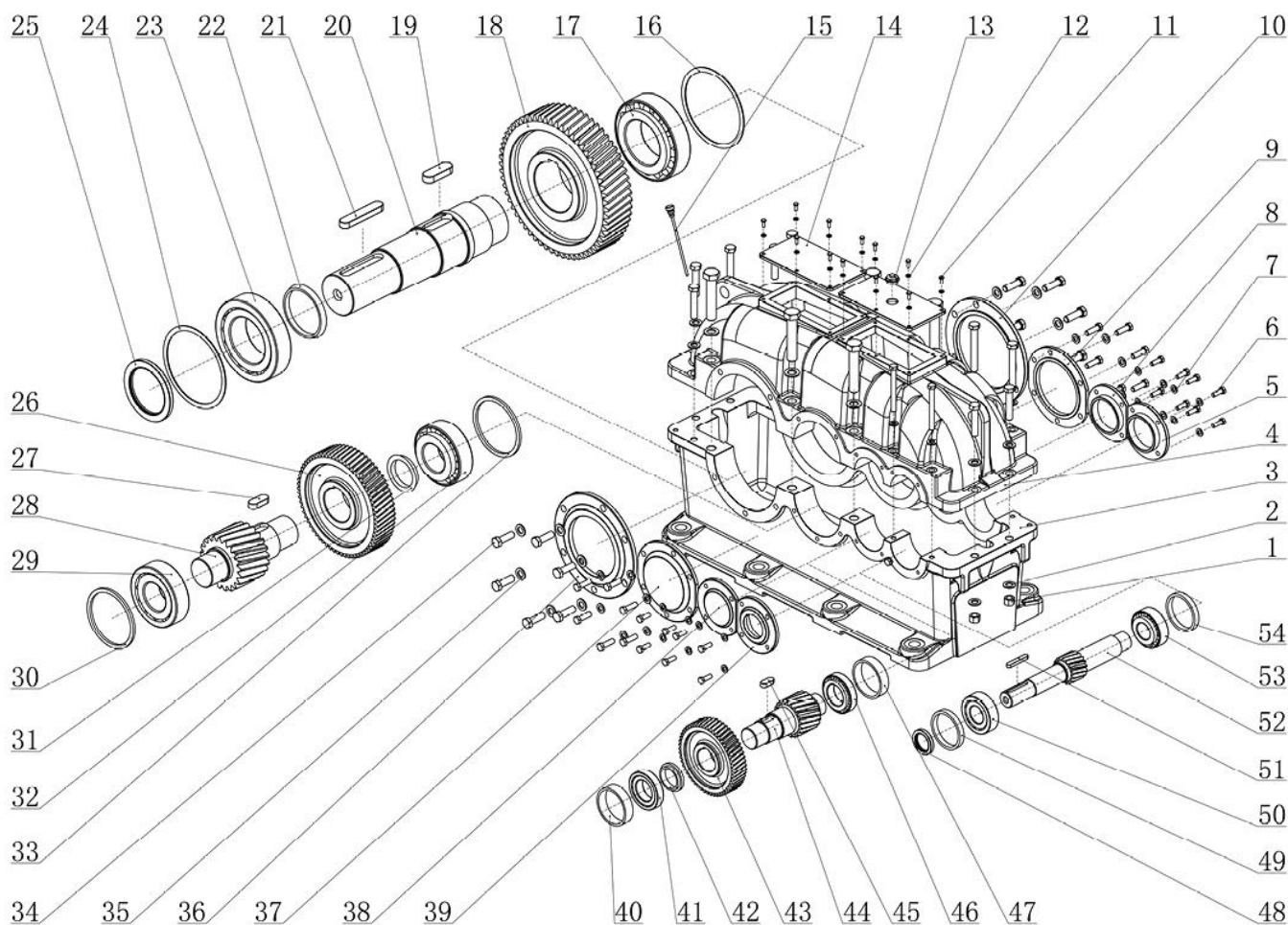

ZDY/DBY系列爆炸图

1.螺母	15.油尺	29.轴承	43.齿轮
2.平垫圈	16.垫圈	30.垫圈	44.齿轴
3.下箱体	17.轴承	31.轴套	45.平键
4.上箱体	18.齿轮	32.轴承	46.轴承
5.端盖	19.平键	33.垫圈	47.垫圈
6.螺栓	20.输出轴	34.螺栓	48.骨架油封
7.平垫圈	21.平键	35.平垫圈	49.垫圈
8.端盖	22.轴套	36.端盖	50.轴承
9.端盖	23.轴承	37.端盖	51.平键
10.端盖	24.垫圈	38.端盖	52.输入轴
11.螺栓	25.骨架油封	39.端盖	53.轴承
12.平垫圈	26.齿轮	40.垫圈	54.垫圈
13.通气帽	27.平键	41.轴承	
14.箱盖	28.齿轴	42.轴套	

YFZDY、YFDBY系列圆柱、圆锥齿轮减速机

YFZDY、YFDBY Series Cone-column Gear Reducer

硬齿面圆柱齿轮减速机是按国家标准生产和设计的,其中心距,公称传动比的主要参数均优化设计,其主要零件能互换,能使交货周期缩短。本机齿轮均采用优质合金钢,经渗碳、淬火、磨齿等工艺使其达到精度高,承载能力大,效率高、寿命长、传动平稳、噪音低。一般冷却采用浸油润滑,在特殊情况下可安装风扇,冷却盘管和油泵循环冷却。本机分为平行轴式:单级YFZDY双级YFZLY三级YFZSY直交式YFDBY(双级)YFDCY(三级)。



YFDBY型、YFDCY型
YFDBY、YFDCY types

YFZDY型、YFZLY型、YFZSY型
YFZDY、YFZLY、YFZSY types

圆锥圆柱齿轮减速机 Cone-column Gear Reducer

DBY型、DBYK型/DBY、DBYK types
DCY型、DCYK型/DCY、DCYK types

技术参数/Technical Data

传动比 Transmission Ratio	双级/Double 8 ~ 14 三级/Triple 16 ~ 50
正反旋向、四种装配型式 Forward and Reverse Rotation, 4 Mounting Ways	

圆柱齿轮减速机 Column Gear Reducer

ZDY、ZLY、ZSY型/ZDY、ZLY、ZSY types

技术参数/Technical Data

传动比 Transmission Ratio	单级/Single 1.25 ~ 6.3
	双级/Double 6.3 ~ 20
	三级/Triple 22.4 ~ 100

Manufactured under national standards, its parameters like center distance and nominal transmission ratio have been advantaged while design. Its main parts are common for use to shorten the delivery time. Made of premium alloy-steel that's hardened by carbon penetration and ground precisely. Large in load, high in efficiency, long in service life stable in running, and low in noise. Usually, dip-feed lubrication for cooling; for special purpose, a fan, cooling coil or oil pump for circulation is equipped for cooling. For parallel-axes structure: YFZDY for single type, YFZLY for double type and YFZSY for triple type; for direct-joint structure: YFDBY for double type and YFDCY for triple type.

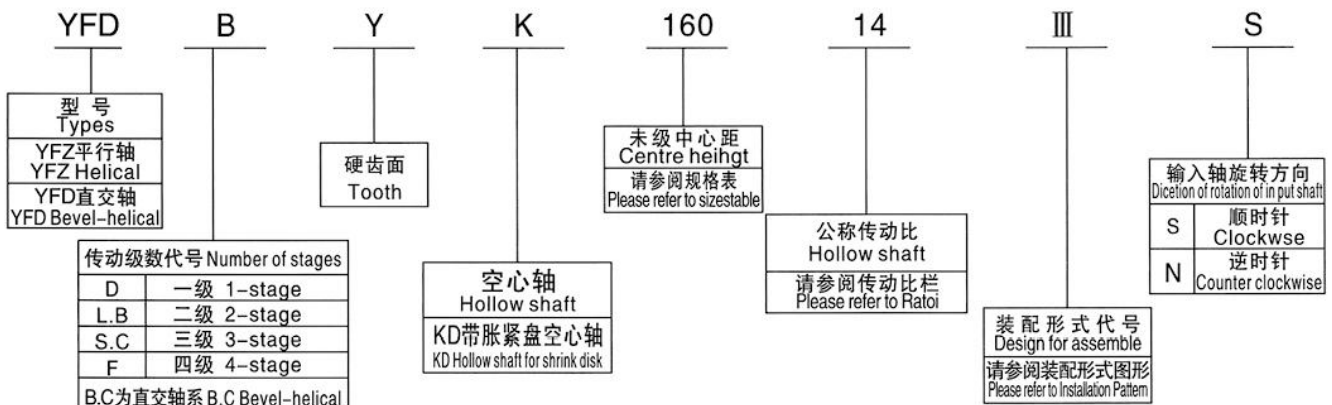

减速器承载能力 Gear units loading

- 1、YFZDY减速器，按机械强度计算的公称功率 P_A 见表1，按润滑油允许最高平衡温度计算的公称热功率 P_{G1} 、 P_{G2} 见表2。
 - 2、YFZLY减速器，按机械强度计算的公称功率 P_A 见表3，按润滑油允许最高平衡温度计算的公称热功率 P_{G1} 、 P_{G2} 见表4。
 - 3、YFZSY减速器，按机械强度计算的公称功率 P_A 见表5，按润滑油允许最高平衡温度计算的公称热功率 P_{G1} 、 P_{G2} 见表6。
 - 4、YFZFY减速器，按机械强度计算的公称功率 P_A 见表7，按润滑油允许最高平衡温度计算的公称热功率 P_{G1} 、见表8。
 - 5、YFDBY、YFDBYK型减速器公称功率 P_A 见表9，热功率 P_{G1} 见表10。
 - 6、YFDCY、YFDCYK型减速器公称功率 P_A 见表11，热功率 P_{G1} 见表12。
- 1、YFZDY Gear units nominal capacity calculated based on mechanical strength P_{Asee1} . Nominal heat calculated based on lubricant oil allowed maximum balance temperature see P_{G1} 、 P_{G2} .
- 2、YFZLY Gear units nominal capacity calculated based on mechanical strength P_{Asee3} . Nominal heat calculated based on lubricant oil allowed maximum balance temperature see P_{G1} 、 P_{G2} .
- 3、YFZSY Gear units nominal capacity calculated based on mechanical strength P_{Asee5} . Nominal heat calculated based on lubricant oil allowed maximum balance temperature see P_{G1} 、 P_{G2} .
- 4、YFZFY Gear units nominal capacity calculated based on mechanical strength P_{Asee7} . Nominal heat calculated based on lubricant oil allowed maximum balance temperature see P_{G1} 、 P_{G2} .
- 5、YFDBY、YFDBYK Gear units Nom power Ratings P_{Asee9} . Thermal capacity see P_{G1} 、 P_{G2} .
- 6、YFDCY、YFDCYK Gear units Nom power Ratings P_{Asee11} . Thermal capacity see P_{G1} 、 P_{G2} .

表 1 YFZDY减速器功率 P_A Table 1 YFZDY Gear units

公称传动比 i Ratio	公称转速 Speed		规 格 Size												
	输入 n_1 Input	输出 n_2 Output	80	100	125	160	200	250	280	315	355	400	450	500	560
	r/min		公 称 输 入 功 率 kW Input power												
1.25	1500	1200	57	103	205	360	633	1121							
	1000	800	40	69	140	260	446	807							
	750	600	31	52	105	190	348	636							
1.4	1500	1070	53	96	194	326	616	1109							
	1000	715	37	65	132	240	433	794							
	750	535	29	48	102	180	337	624							
1.6	1500	940	49	92	180	310	587	1068	1473	1996	2766				
	1000	625	34	63	125	217	410	760	1051	1430	1992				
	750	470	27	50	98	168	319	595	824	1124	1569				
1.8	1500	835	45	87	173	290	557	1024	1411	1925	2663				
	1000	555	31	62	120	206	389	726	1002	1372	1906				
	750	415	24	48	95	160	302	567	784	1074	1497				
2	1500	750	39	80	158	278	526	970	1339	1827	2536				
	1000	500	27	55	110	194	367	684	946	1296	1806	2547	3578	4793	
	750	375	21	43	85	150	284	534	738	1013	1414	1999	2821	3775	5169
2.24	1500	670	36	70	141	264	484	914	1236	1711	2477				
	1000	445	25	49	98	183	337	645	874	1207	1683	2402	3397	4512	
	750	335	19	38	76	142	262	503	682	941	1314	1878	2667	3538	4833

续表 1
Table 1

公称传动比 Ratio	公称转速 Speed		规格 Size												
	输入 n_1 Input	输出 n_2 Output	80	100	125	160	200	250	280	315	355	400	450	500	560
	r/min		公称输入功率 kW Input Power												
2.5	1500	600	32	64	127	245	447	855	1154	1617	2264				
	1000	400	22	45	88	170	311	601	812	1136	1596	2235	3182	4353	
	750	300	17	35	68	132	241	468	633	884	1243	1742	2492	3406	4645
2.8	1500	535	27	53	115	224	409	789	1063	1489	2068				
	1000	360	19	37	80	155	284	552	746	1048	1456	2049	2945	4000	
	750	270	15	29	62	120	220	429	580	816	1134	1593	2296	3118	4232
3.15	1500	475	23	47	96	203	375	709	990	1359	1924	2658	3790	5036	6666
	1000	315	16	33	67	140	260	496	695	952	1352	1817	2681	3607	4807
	750	235	13	25	52	109	202	385	540	740	1052	1458	2084	2802	3747
3.55	1500	425	20	41	85	179	337	639	898	1210	1730	2410	3407	4460	6119
	1000	280	14	28	59	124	234	446	628	845	1210	1694	2396	3196	4395
	750	210	11	22	46	96	181	346	488	655	940	1312	1856	2483	3419
4	1500	375	17	34	69	155	300	570	774	1095	1555	2146	2981	3985	5651
	1000	250	12	24	48	107	208	396	539	764	1088	1501	2090	2838	4033
	750	187	9	18	37	83	161	307	418	590	844	1160	1618	2199	3128
4.5	1500	355	14	29	55	137	260	495	703	997	1367	1878	2619	3635	4912
	1000	220	9.5	20	38	95	180	344	488	694	953	1311	1832	2582	3485
	750	166	7	15	30	73	139	266	378	536	738	1015	1416	1997	2694
5	1500	300	11	25	48	121	229	451	608	864	1179	1680	2340	3149	4400
	1000	200	8	17	33	84	159	313	422	599	820	1168	1629	2231	3125
	750	150	6	13	26	65	123	242	326	462	633	900	1257	1724	2418
5.6	1500	270	10	20	40	109	211	389	531	779	1031	1564	2038	2791	3778
	1000	180	7	14	27	75	146	270	368	540	716	1088	1417	1969	2670
	750	134	5	11	21	59	113	208	285	416	554	838	1092	1519	2061
6.3	1500	240		16	36	90	175	353	465	651	944	1313	1804	2547	3342
	1000	160		11	25	63	121	244	322	451	655	911	1252	1795	2356
	750	120		9	19	49	94	189	249	349	507	704	964	1388	1817

表2 YFZDY 减速器热功率 P_{G1} 、 P_{G2}
Table 2 YFZDY Gear Units Thermal Capacities P_{G1} 、 P_{G2}

散热冷却条件 Cooling conditions		规格 Size																							
		80	100	125	160	200	250	280	315	355	400	450	500	560											
没有冷却措施 Without auxiliary cooling	环境条件 Ambient conditions	环境气流速度W Wind velocity P_{G1} kW																							
	空间小、厂房小 Small confined spaces												13	20	31	48	77	115	145	182	228	286	365	440	542
	较大的房间、车间 Large halls workshops												18	29	43	68	110	160	210	270	320	415	515	620	770
	在户外露天 In the open												24	38	58	92	145	220	275	360	425	550	690	840	1020
盘状管冷却或循环油润滑 Cooling or cycling oil lubrication for coil pipes	环境条件 Ambient conditions	水管内径d Pipe interior diameter 环境气流速度W Ambient airflow speed P_{G2} kW																							
	空间小、厂房小 Small confined spaces												0.08	0.08	0.08	0.12	0.12	0.15	0.15	0.20	0.20	0.20	0.20	0.20	0.20
	较大的房间、车间 Large halls workshops												43	65	90	180	300	415	490	610	695	870	1010	1190	1300
	在户外露天 In the open												48	75	100	200	330	465	550	695	790	1000	1160	1380	1530
		54	90	120	220	365	520	625	790	900	1140	1340	1600	1780											

注：当采用循环油润滑时，可按润滑系统计算适当提高 P_{G1} 。
Note: in case of cycling oil lubrication, improve P properly based on calculation in lubrication system.

表3 YFZLY 减速器功率 P_A
Table 3 YFZLY Gear Units Power P_A

公称传动比 Ratio	公称转速 Speed	规格 Size																			
		输入n ₁ Input	输出n ₂ Output	112	125	140	160	180	200	224	250	280	315	355	400	450	500	560	630	710	
r/min		公称输入功率KW Input Power																			
6.3	1500	240	37.4	54	73	114	157	221	305	424	578	791	1156	1650	2192	3132	4310				
	1000	160	26.4	37.4	50	78	109	153	211	294	400	548	802	1146	1558	2181	3000	4347	6229		
	750	120	19.54	28.6	38.5	60	84	119	163	227	308	422	618	884	1213	1685	2320	3357	4884		
7.1	1500	210	34	49	66	104	143	201	277	385	525	719	1051	1500	1993	2847	3817				
	1000	140	24	34	45.5	71	99	139	192	267	364	498	729	1042	1416	1983	2731	3952	5663		
	750	106	17.7	26	35	54.5	76	108	148	206	280	384	562	804	1103	1532	2109	3052	4440		
8	1500	185	32	43	61	94.5	130	181.5	250	347	469	678	932	1309	1869	2489	3520				
	1000	125	21.5	29.5	42.4	64	93	126	173	241	325	470	646	908	1298	1730	2447	3398	5019		
	750	94	17	23	33	49	69	97	133	186	251	362	498	700	1000	1333	1887	2619	3881		
9	1500	167	29	38.5	56	81	119	165.5	227	315	423	612	841	1182	1689	2248	3183				
	1000	111	20	27	38.5	55	82.5	115	157	218	293	424	583	819	1172	1561	2210	3068	4537		
	750	83	15	20.5	30	42	64	88	121	168	226	327	449	631	903	1202	1703	2363	3502		
10	1500	150	26	35	50	73	109	149	204	284	383	555	762	1070	1530	2038	2883				
	1000	100	18	24	35	50	75	103	142	197	266	384	528	742	1061	1414	2001	2777	4112		
	750	75	14	18.5	26.6	38	58	80	109	152	204	296	407	571	817	1088	1541	2139	3172		
11.2	1500	134	23	31.5	45	66	96	133	184	255	346	500	688	966	1381	1839	2604				
	1000	89	16	22	31	45	67	92	127	177	240	347	477	669	957	1275	1806	2506	3711		
	750	67	12	17	24	35	51	71	98	136	185	267	367	516	737	982	1391	1930	2862		

续表 3
Table 3

公称传动比 Ratio	公称转速 Speed		规格 Size																
	输入 n_1 Input	输出 n_2 Output	112	125	140	160	180	200	224	250	280	315	355	400	450	500	560	630	710
			公称输入功率KW Input Power																
			r/min																
12.5	1500	120	21	28	40	59	83	116.5	165	229	311	450	618	869	1242	1654	2341		
	1000	80	14	19.5	28	40	57	81	114	159	216	312	428	601	860	1146	1621	2251	3338
	750	60	11	15	21	31	44	63	88	122	166	240	330	463	663	882	1249	1734	2573
14	1500	107	18.5	25	36	52.5	74	105	148	206	279	404	555	779	1115	1485	2162	2918	4318
	1000	71	12.5	17.6	25	36	51	73	102	142	193	280	384	540	772	1028	1455	2020	2996
	750	54	9.8	13	19	27.6	39	56	79	110	149	216	296	416	594	792	1120	1555	2310
16	1500	94	16	22	31	47.5	70.5	98	133	185	251	362	498	700	1000	1333	1887	2619	3879
	1000	62	11	15	21.5	32	49	68	92	128	174	251	345	484	693	923	1306	1812	2690
	750	47	8	11.5	17	25	38	53	71	99	134	193	266	373	533	711	1005	1395	2073
18	1500	83	14	19.5	28	42.5	60.5	86	115	161	225	326	448	629	899	1197	1697	2353	3487
	1000	56	10	13.5	19.6	29	42	59.5	80	111	156	226	310	435	622	829	1175	1628	2417
	750	42	7.5	10.5	15	22	32	46	61	86	120	174	239	335	479	638	905	1252	1861
20	1500	75	13	18	25.5	38	59	77	103	142	205	296	418	587	839	1120	1580	2200	3260
	1000	50	9	12	28	26.5	41	53.5	72	95	142	205	279	392	560	746	1050	1460	2170
	750	38	6.8	9.5	14	20	32	41	55	76	109	158	210	295	420	562	735	1120	1635

表4 YFZLY 减速器热功率 P_{G1} 、 P_{G2}
Table 4 YFZLY Gear Units Thermal Capacities P_{G1} 、 P_{G2}

散热冷却条件 Cooling conditions		规格 Size																
		112	125	140	160	180	200	224	250	280	315	355	400	450	500	560	630	710
没有冷却措施 Without auxiliary cooling	环境条件 Ambient conditions	P_{G1} KW																
	环境气流速度W Wind velocity																	
	空间小、厂房小 Small confined spaces																	
盘状管冷却或循环油润滑 Cooling or cycling oil lubrication for coil pipes	环境条件 Ambient conditions	P_{G2} KW																
	环境气流速度W Wind velocity																	
	空间小、厂房小 Small confined spaces																	
较大的房间、车间 Large halls workshops	环境条件 Ambient conditions	P_{G2} KW																
	环境气流速度W Wind velocity																	
	较大的房间、车间 Large halls workshops																	
在户外露天 In the open	环境条件 Ambient conditions	P_{G2} KW																
	环境气流速度W Wind velocity																	
	在户外露天 In the open																	
水管内径 d Pipe interior diameter	环境条件 Ambient conditions	P_{G2} KW																
	环境气流速度W Wind velocity																	
	水管内径 d Pipe interior diameter																	

注：当采用循环油润滑时，可按润滑系统计算适当提高 P_{G1} 。
Note: in case of cycling oil lubrication, improve P properly based on calculation in lubrication system.

表5 YFZSY 减速器功率 P_A
Table5 YFZSY Gear Units Power P_A

公称传动比 Ratio	公称转速 Speed		规格 Size													
	输入 n_1 Input	输出 n_2 Output	160	180	200	224	250	280	315	355	400	450	500	560	630	710
	r/min		公称输入功率 kW Input Power													
22.4	1500	67	34	51	68	98	131	182	270	400	530	780	1065	1450	1865	
	1000	44	24	35	48	68	91	128	185	262	355	540	750	1025	1325	1905
	750	33	18	27	37	52	70	97	135	215	275	415	580	800	1030	1485
25	1500	60	32	46	63	96	115	157	240	365	470	705	1020	1405	1865	
	1000	40	22	31	43	66	80	108	163	250	315	465	705	975	1325	1905
	750	30	16	24	33	51	60	84	122	195	240	350	540	750	1030	1485
28	1500	54	29	42	59	86	113	142	220	325	425	625	945	1260	1800	
	1000	36	20	29	41	60	75	98	148	215	280	420	650	870	1245	1760
	750	27	15	22	31	46	56	76	114	160	210	310	500	670	960	1355
31.5	1500	48	26	37	51	79	95	127	197	290	395	560	840	1140	1600	
	1000	32	17	26	35	55	63	86	132	195	370	370	585	790	1110	1565
	750	24	14	20	27	42	49	65	100	145	200	280	450	605	855	1200
35.5	1500	42	23	34	47	70	88	117	178	275	350	510	755	1025	1450	
	1000	28	15	23	32	48	59	80	118	180	235	340	520	710	1000	1410
	750	21	12	18	25	37	44	61	90	140	175	255	405	545	750	1090
40	1500	38	21	30	42	64	79	107	158	235	325	465	675	930	1300	
	1000	25	17	21	29	40	53	71	108	160	210	315	465	640	900	1315
	750	19	11	16	22	31	41	55	80	125	155	235	360	465	680	1015
45	1500	33	17	24	34	46	70	96	142	215	280	410	615	850	1130	
	1000	22	12	16	24	32	47	64	95	145	185	280	425	590	770	1150
	750	17	9	12	18	25	36	50	74	110	140	210	320	450	600	885
50	1500	30	15	22	32	46	63	85	128	195	245	360	540	750	1030	1490
	1000	20	11	15	22	31	43	59	85	130	165	240	370	520	710	1030
	750	15	8	12	17	24	32	43	65	95	125	180	290	400	550	795

续表 5
Table 5

公称传动比 Ratio	公称转速 Speed		规格 Size													
	输入 n_1 Input	输出 n_2 Output	160	180	200	224	250	280	315	355	400	450	500	560	630	710
	r/min		公称输入功率 kW Input Power													
56	1500	27	15	21	31	43	56	76	112	170	220	310	480	675	955	1340
	1000	18	10	15	22	30	38	52	77	115	145	210	330	470	660	930
	750	13.4	8	11	17	23	28	40	58	90	110	160	255	360	510	715
63	1500	24	12	17	23	37	45	61	102	145	195	280	425	605	860	1170
	1000	16	8	12	16	25	30	42	70	100	130	190	290	420	600	810
	750	12	6	9	12	20	23	32	52	75	100	140	225	325	460	620
71	1500	21	11	17	23	33	40	56	90	130	185	245	390	540	770	1045
	1000	14	8	11	15	23	27	38	60	90	115	170	270	370	540	725
	750	10.6	6	9	12	18	21	29	45	65	90	125	210	285	410	555
80	1500	18.8	9	13	18	26	36	51	80	115	155	225	340	470	675	960
	1000	12.5	6	9	12	18	24	34	54	80	100	150	240	330	470	665
	750	9.4	4	7	10	14	19	27	42	60	80	110	185	250	360	510
90	1500	16.7	8	12	18	25	33	46	74	105	140	200	305	395	590	765
	1000	11.1	6	8	12	17	22	30	49	70	95	130	200	278	405	530
	750	8.3	4	6	9	13	17	23	37	55	70	100	160	210	300	405
100	1500	15	8	11	16	24	30	43	60							
	1000	10	5	7	11	16	21	29	40							
	750	7.5	4	6	8	13	16	22	30							

表6 YFZSY 减速器热功率 P_{G1} 、 P_{G2}
Table 6 YFZSY Gear Units Thermal Capacities P_{G1} 、 P_{G2}

散热冷却条件 Cooling conditions		规格 Size																									
		160	180	200	224	250	280	315	355	400	450	500	560	630	710												
环境条件 Ambient conditions	环境气流 速度W Wind velocity	P_{G1} KW																									
	空间小、厂房小 Small confined spaces													24	30	37	45	56	69	86	110	135	165	208	253	322	400
	较大的房间、车间 Large halls workshops													34	42	52	64	80	98	116	155	190	235	300	365	450	570
没有冷却措施 Without auxiliary cooling	在户外露天 In the open	46	57	69	87	108	132	162	205	250	310	400	475	600	760												
	水管内径 d Pipe interior diameter	0.15	0.15	0.15	0.15	0.15	0.15	0.15	0.20	0.20	0.20	0.20	0.20	0.20	0.20												
	环境条件 Ambient conditions	P_{G2} KW																									
空间小、厂房小 Small confined spaces	70													77	92	106	150	160	180	210	255	310	370	430	480	560	770
较大的房间、车间 Large halls workshops	80													89	107	125	175	190	210	255	310	370	440	520	590	700	940
盘状管冷却或循环油润滑 Cooling or cycling oil lubrication for coil pipes	在户外露天 In the open	90	105	124	148	200	225	255	310	370	440	510	620	700	970	1150											
	环境气流 速度W Wind velocity	P_{G2} KW																									
空间小、厂房小 Small confined spaces	70													77	92	106	150	160	180	210	255	310	370	430	480	560	770
较大的房间、车间 Large halls workshops	80	89	107	125	175	190	210	255	310	370	440	520	590	700	940												
在户外露天 In the open	90	105	124	148	200	225	255	310	370	440	510	620	700	970	1150												

表7 YFZFY 减速器功率 P_A
Table 7 YFZFY Gear Units Power P_A

公称传动比 Ratio	公称转速 Speed		规格 Size												
	输入 n_1 Input	输出 n_2 Output	160	180	200	250	280	315	355	400	450	500	560	630	710
	r/min		公称输入功率 kW Input Power												
100	1500	15							99	130	190	290	400	540	780
	1000	10							66	87	125	195	265	360	520
	750	7.5							50	65	95	145	205	270	400
112	1500	13.4	9.2	15	21	29	40	59	88	115	170	255	360	480	690
	1000	8.9	6.1	10	14	20	27	40	59	78	115	170	240	320	470
	750	6.7	4.6	7.5	11	15	20	29	44	59	85	130	185	245	355
125	1500	12	9.2	12	18.5	26	36	52	81	105	150	230	320	430	610
	1000	8	6.1	8	12.5	17.5	24	35	54	70	100	155	215	285	410
	750	6	4.6	6	9.3	13	18	26.5	41	53	75	115	165	215	310
140	1500	10.7	8.4	11	16.5	23	32	46	72	92	135	205	290	380	550
	1000	7.1	5.9	7.3	11	16	21.5	31	48	61	90	135	195	255	370
	750	5.4	4.2	5.5	8.3	12	16	23	36	46	68	105	145	190	280
160	1500	9.4	7.5	9.6	14.5	20	28	41	64	81	120	180	255	340	490
	1000	6.3	5	6.4	9.7	14	18.5	27.5	43	54	80	120	170	255	330
	750	4.7	3.8	4.8	7.6	10	14	21	32	41	60	92	130	170	250
180	1500	8.3	6.6	8.4	13	19	25	37	57	70	105	160	225	300	440
	1000	5.6	4.4	5.6	8.7	12.5	17	25	38	47	70	105	150	200	295
	750	4.2	3.3	4.2	6.5	9.5	13	18.5	29	35	53	82	115	155	220
200	1500	7.5	5.6	7.5	12	15.5	22	33	51	64	95	145	205	275	390
	1000	5	3.7	5	8	10.5	14.5	22	34	43	63	97	135	280	260
	750	3.8	2.8	3.8	6	8	11.5	17	26	32	48	73	105	135	200
224	1500	6.7	4.8	6.7	10.5	14	20	29	45	57	83	130	185	240	360
	1000	4.5	3.2	4.5	7	9.3	13.5	20	30	38	55	87	125	160	240
	750	3.3	2.4	3.4	5.3	7	10.5	15	23	28.5	42	66	94	120	180
250	1500	9	4.5	6.1	9.5	12.5	17.5	26	41	51	73	115	165	215	320
	1000	4	3	4.1	6.3	8.5	12	17.5	27.5	34	49	77	110	145	215
	750	3	2.3	3.1	4.8	6.5	9	13	20.5	25.5	37	58	83	110	160
280	1500	5.4	3.9	5.3	8.2	11	15.5	23	37	46	66	100	145	195	280
	1000	3.6	2.6	3.5	5.6	7.5	10.5	17.5	24.5	31	44	67	97	130	185
	750	2.7	2	2.7	4.2	5.6	8	12	19	23	34	51	73	96	140
315	1500	4.8	3.5	4.7	7.5	9.5	13.5	21	32	42	59	92	130	175	250
	1000	3.2	2.3	3.1	5.1	6.5	9	14	21.5	28	39	61	87	115	165
	750	2.4	1.8	2.4	3.8	5	7	10.5	16.5	21	30	47	66	88	125
355	1500	4.2	2.9	4	6.5	8.5	12	18	29	37	52	83	135	155	225
	1000	2.8	1.9	2.7	4.5	6	8.5	12	19.5	24.5	35	55	77	105	150
	750	2.1	1.5	2	3.3	4.5	6.5	9.5	14.5	18.5	26.5	42	59	78	115
400	1500	3.8	2.6	3.6	6	8	11	16.5	26	33	46	73	100	115	195
	1000	2.5	1.7	2.4	4	5.3	7.5	11	17.5	22	31	48	68	90	130
	750	1.9	1.3	1.8	3	4	5.6	8.3	13.5	16.5	23.5	37	52	68	99
450	1500	3.3	2.3	3.2	5	7	10	13.5	21.5	29	40	65	93	125	175
	1000	2.2	1.5	2.1	3.5	4.7	6.6	9	14.5	19.5	26.5	44	62	83	115
	750	1.7	1.2	1.6	2.6	3.5	5.1	6.8	11	14.5	20	33	47	63	89
500	1500	3	2.1	2.9	4.2	6	9.1	12	19.5	26	36	59	82	110	155
	1000	2	1.4	1.9	2.8	4	6.1	8	13	17.5	24	36	55	73	105
	750	1.5	1.1	1.5	2.1	3	4.6	6	9.6	13	18	30	42	55	79

表8 YFZFY 减速器热功率 P_{G1}
Table 8 YFZFY Gear Units Thermal Capacities P_{G1} , P_{G2}

环境、冷却情况 Ambient conditions		空气流速 Wind velocity	齿轮箱规格 Size												
			160	180	200	250	280	315	355	400	450	500	560	630	710
			热功率 kW Thermal capacities kW												
P_{G1}	安装场地小， 无冷却装置 Without auxiliary cooling Small confined spaces	$W \geq 0.5m/s$	27	38	41	52	64	78	99	120	150	190	230	290	360
	安装场地大， 无冷却装置 Without auxiliary cooling Large halls wordshops	$W \geq 1.4m/s$	39	47	59	74	90	110	140	170	210	265	330	410	510
	室外无冷却装置 Without auxiliary cooling in the open	$W \geq 3.7m/s$	52	62	78	98	120	145	190	230	280	360	430	550	680

注：如果按照“热功率校核计算”需要采用冷却装置，必须加以说明。
Note: If the thermal power calibration needs for a cooling device, must be clarified.

表9 YFDBY, YFDBYK型减速器功率 P_A
Table 9 YFDBY, YFDBYK Gear Units Power P_A

公称传动比 Ratio	公称转速 Speed		名义中心距 Centre height											
	输入 n_1 Input	输出 n_2 Output	160	180	200	224	250	280	315	355	400	450	500	560
	r/min		公称输入功率 kW Input Power											
8	1500	188	81	115	145	205	320	435	610	750	1080	1680 [△]	2100 [△]	-
	1000	125	56	86	110	155	245	325	465	560	810	1260	1700	2200
	750	94	42	55	88	125	185	250	340	465	660	950	1400	1800
10	1500	150	67	92	130	165	255	345	480	610	910	1370	1900 [△]	-
	1000	100	44	69	94	125	195	260	360	465	620	950	1270	1700
	750	75	34	46	73	105	155	210	295	380	510	710	950	1300
11.2	1500	134	59	81	115	150	235	325	450	560	840	1200	1550	-
	1000	89	40	61	84	130	175	245	340	430	630	810	1030	1380
	750	67	31	41	65	98	140	185	240	354	470	610	780	1040
12.5	1500	120	53	75	105	140	210	285	390	500	760	980	1260	1550 [△]
	1000	80	36	56	74	105	145	215	265	380	480	660	850	1110
	750	60	27	36	56	76	110	150	190	270	365	500	640	840
14	1500	107	48	66	81	125	190	260	345	465	580	780	1000	1150 [△]
	1000	71	31	42	54	84	110	165	205	310	415	520	680	900
	750	53	23	31	38	60	80	115	145	235	310	400	510	690

注: △ 需采用循环油润滑

Note: △ in case of cycling oil lubrication

表10 YFDBY, YFDBYK型减速器热功率 P_{G1}
Table 10 YFDBY, YFDBYK Gear Units Power P_{G1}

环境条件 Ambient conditions	空气流速 Wind velocity m/s	名义中心距 a											
		160	180	200	224	250	280	315	355	400	450	500	560
减速器不附加冷却装置的热功率 P_{G1} , kW Without auxiliary cooling Thermal capacities P_{G1} , kW													
狭小空间内 Small confined spaces	≥ 0.5	32	40	50	61	76	95	118	143	180	225	279	355
中、大型车间内 Large halls workshops	≥ 1.4	45	57	71	85	106	133	165	201	252	316	391	497
室外 In the open	≥ 3.7	62	77	96	116	144	181	224	272	342	429	531	675

注: 减速器附装冷却管时的热功率 P_{G2} , 可根据需要进行设计。

Note: Thermal power of reducer with cooling tube (P_{G2}) can be designed according to the demand.

表11 YFDCY,YFDCYK型减速器功率 P_A
Table 11 YFDCY,YFDCYK Gear Units Power P_A

公称传动比 Ratio	公称转速 Speed		名义中心距 Centre height														
	输入n ₁ Input	输出n ₂ Output	160	180	200	224	250	280	315	355	400	450	500	560	630	710	800
	r/min		公称输入功率 kW Input Power														
16	1500	94	45	61	80	120	160	230	305	440	600 [△]	830 [△]	1350 [△]	1850 [△]			
	1000	63	30	43	60	85	115	170	230	330	440	630	1010	1420 [△]	2200 [△]	2500 [△]	2850
	750	47	24	35	45	70	85	140	185	270	360	510	830	1180	1600	2300 [△]	2600
18	1500	83	42	58	75	110	150	210	290	440	560	780 [△]	1350 [△]	1850 [△]	-	-	-
	1000	56	30	40	53	75	105	155	215	330	420	590	1000	1400	1860 [△]	2500 [△]	2850 [△]
	750	42	23	32	42	65	80	120	175	260	345	480	790	1120	1460	2180 [△]	2500
20	1500	75	39	53	68	100	135	195	270	430	550	780 [△]	1320 [△]	1800 [△]	-	-	-
	1000	50	27	36	48	70	95	140	200	315	380	550	880	1240 [△]	1640 [△]	2400 [△]	2850 [△]
	750	38	20	28	38	55	75	110	160	245	310	445	700	1000	1290	1920 [△]	2500 [△]
22.4	1500	67	34	50	65	94	130	175	250	400	510	730	1170 [△]	1540 [△]	-	-	-
	1000	45	23	34	48	65	90	130	185	290	360	520	780	1100	1450 [△]	2120 [△]	2600 [△]
	750	33	17	25	36	49	70	95	140	220	275	400	620	880	1140	1710	2460 [△]
25	1500	60	30	44	62	83	115	160	225	350	460	650	1030	1460 [△]	-	-	-
	1000	40	20	30	42	57	80	110	165	255	315	460	730	1040	1350 [△]	2010 [△]	2600 [△]
	750	30	15	23	32	43	60	85	125	195	240	350	550	780	1010	1510	2180 [△]
28	1500	54	22	37	48	75	92	140	215	320	405	590	910	1290 [△]	-	-	-
	1000	36	15	25	34	52	66	94	150	225	285	420	640	910	1190	1770 [△]	2500 [△]
	750	27	12	19	26	39	50	71	115	170	215	315	490	690	890	1330	1920 [△]
31.5	1500	48	20	33	44	69	85	120	195	290	385	550	820	1170	-	-	-
	1000	32	14	22	31	46	59	83	130	200	255	370	580	920	1070	1600 [△]	2310 [△]
	750	24	10	17	23	34	44	62	100	150	190	280	440	620	800	1200	1740 [△]
35.5	1500	42	18	30	40	62	77	110	180	260	345	500	770	1100	1430	2120	-
	1000	28	12	20	28	42	53	75	120	180	230	340	510	720	950	1410	2030 [△]
	750	21	9	15	21	31	40	56	90	135	175	250	385	540	710	1060	1540 [△]
40	1500	38	17	27	36	56	69	98	160	235	310	450	690	990	1290 [△]	1920	-
	1000	25	11	18	25	41	47	67	120	160	225	330	465	660	860	1280 [△]	1850 [△]
	750	19	8.5	14	19	29	36	52	82	125	155	230	350	495	640	960	1390 [△]
45	1500	33.5	15	24	33	50	64	90	145	215	275	400	620	880	1150	1720 [△]	2100 [△]
	1000	22	10	16	22	33	42	60	95	145	180	265	455	640	840	1250	1810
	750	16.6	7.5	12	17	26	32	46	74	110	140	205	320	455	600	870	1260
50	1500	30	13	21	30	44	57	80	130	195	245	360	550	780	1030	1540 [△]	2050 [△]
	1000	20	9	14	20	31	38	54	87	130	165	240	365	520	680	1020	1480
	750	15	7	11	15	23	29	41	65	99	120	180	290	410	540	780	1130

注: △需采用循环油润滑
Note: △ in case of cycling oil lubrication

表12 YFDCY, YFDCYK型减速器热功率 P_{G1}
Table 12 YFDCY, YFDCY Gear Units Thermal Capacities P_{G1}

环境条件 Ambient conditions	空气流速 Wind velocity m/s	名义中心距 a Centre height														
		160	180	200	224	250	280	315	355	400	450	500	560	630	710	800
		减速器不附加冷却装置的热功率 P_{G1} kW Without auxiliary cooling Thermal capacities P_{G1} kW														
狭小空间内 Small confined spaces	≥ 0.5	22	27	34	41	52	65	81	99	124	156	192	245	299	384	482
中、大型车间内 Large halls workshops	≥ 1.4	31	38	48	58	73	91	114	139	174	218	270	343	419	537	675
室外 In the open	≥ 3.7	42	52	65	79	99	124	155	189	237	296	366	465	568	730	910

注：减速器附装冷却管时的热功率 P_{G2} ，可根据需要进行设计。
Note: Thermal power of reducer with cooling tube (P_{G2}) can be designed according to the demand.

规格及选型参数 Size and selection table

YFZDY YFZDZ减速器的装配型式及外形尺寸
YFZDY YFZDZ Gear unit structure and outline dimension sheet

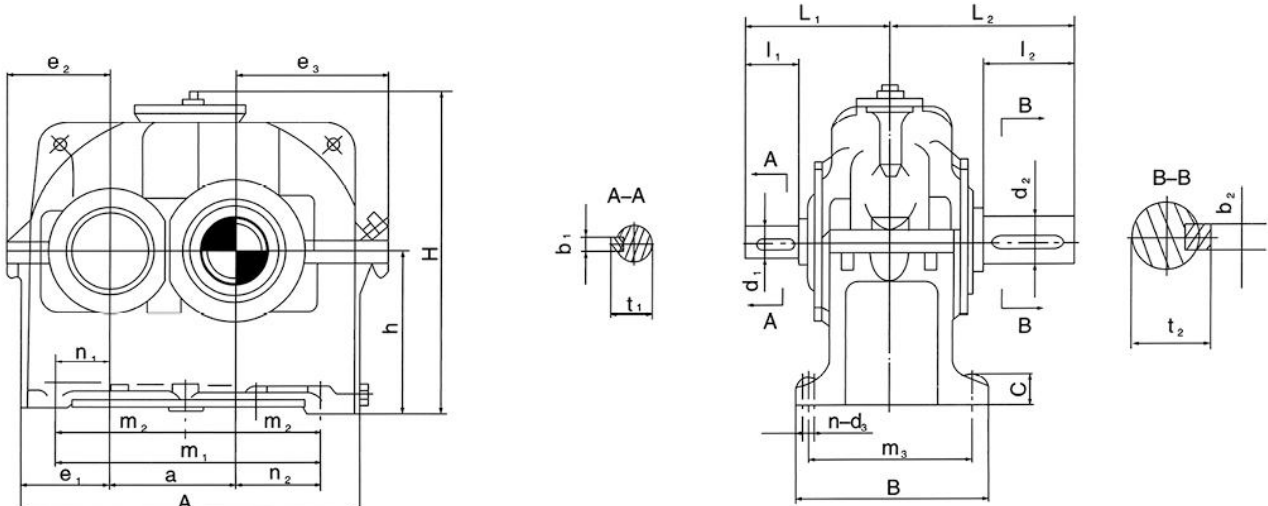

YFZDY YFZDZ型装配型式
YFZDY YFZDZ Design



图1

YFZDY/YFDBY系列 | 外形安装尺寸

Outside dimension sheets-overview

规格 Size	A	B	H	a	i= 1.25 ~ 2.8					i= 3.15 ~ 4.5					i= 5~5.6				
			≈		d ₁ (m ₆)	l ₁	L ₁	b ₁	t ₁	d ₁ (m ₆)	l ₁	L ₁	b ₁	t ₁	d ₁ (m ₆)	l ₁	L ₁	b ₁	t ₁
80	235	150	210	80	28	42	112	8	31	24	36	106	8	27	19	28	98	6	21.5
100	290	175	260	100	42	82	167	12	45	28	42	127	8	31	22	36	121	6	24.5
125	355	195	330	125	48	82	182	14	51.5	38	58	158	10	41	28	42	142	8	31
160	445	245	403	160	65	105	225	18	69	48	82	202	14	51.5	38	58	178	10	41
200	545	310	507	200	80	130	275	22	85	60	105	250	18	64	48	82	227	14	51.5
250	680	370	662	250	400	165	340	28	106	80	130	305	22	85	60	105	280	18	64
280	755	450	722	280	110	165	385	28	116	85	130	350	22	90	65	105	325	18	69
315	840	500	770	315	130	200	445	32	137	95	130	375	25	100	75	105	350	20	79.5
355	930	550	930	355	140	200	470	36	148	100	165	435	28	106	90	130	400	25	95
400	1040	605	982	400	150	200	485	36	158	110	165	450	28	116	95	130	415	25	100
450	1150	645	1090	450	160	240	545	40	169	120	165	470	32	127	100	165	470	28	106
500	1290	710	1270	500	180	240	580	45	190	130	200	540	32	137	120	165	505	32	127
560	1440	780	1360	560	200	280	660	45	210	150	200	580	36	158	130	200	580	32	137
规格 Size	d ₂ (m ₆)	l ₂	L ₂	b ₂	t ₂	C	m ₁	m ₂	m ₃	n ₁	n ₂	e ₁	e ₂	e ₃	h	d ₃	n	重量 kg Weight	润滑 油量 L Lubri- cation
80	32	58	128	10	35	18	180	-	120	40	60	67.5	81	101	100	12	4	14	0.9
100	48	82	167	14	51.5	22	225	-	140	52.5	72.5	85	102	122	125	15	4	35	1.6
125	55	82	182	16	59	25	290	-	160	65	100	97.5	119	155	160	15	4	76	3.2
160	70	105	225	20	74.5	32	355	-	200	73	122	118	141	190	200	18.5	4	115	6.5
200	90	130	275	25	95	40	425	-	255	80	145	140	169	235	250	24	4	228	12.5
250	110	165	340	28	116	50	550	275	305	110	190	175	214	295	315	28	6	400	23
280	130	200	420	32	137	50	620	310	380	120	220	187.5	228	328	355	28	6	540	36
315	140	200	445	36	148	63	700	350	420	137.5	247.5	207.5	254	364	400	35	6	800	45
355	150	200	470	36	158	63	770	385	470	142.5	272.5	222.5	269	397	450	35	6	870	70
400	160	240	525	40	169	80	850	425	510	150	300	245	304	454	500	42	6	1640	90
450	170	240	545	40	179	80	950	475	550	165	335	265	331	501	560	42	6	2100	125
500	190	280	620	45	200	100	1080	540	610	190	390	295	418	618	630	42	6	3100	180
560	240	330	790	56	252	100	1200	600	680	205	435	325	432	662	710	48	6	3730	250

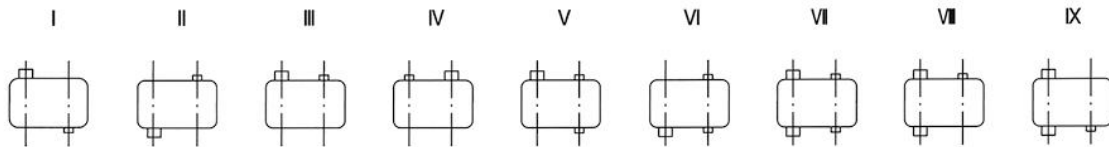
YFZLY、YFZLZ 减速器的装配型式及外形尺寸
YFZLY、YFZLZ Gear unit structure and outline dimension sheet

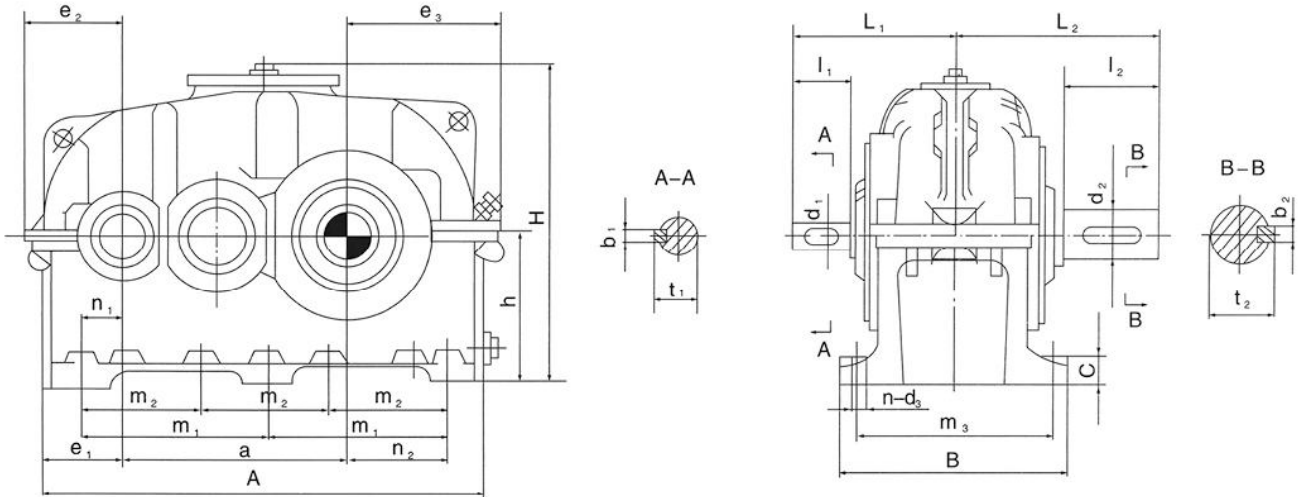

YFZLY、YFZLZ型装配型式

YFZLY YFZLZ Design



图2

规格 Size	A	B	H ≈	a	i = 6.3 ~ 11.2					i = 12.5 ~ 20					d ₂ (m _e)	l ₂	L ₂	b ₂	t ₂
					d ₁ (m _e)	l ₁	L ₁	b ₁	t ₁	d ₁ (m _e)	l ₁	L ₁	b ₁	t ₁					
112	385	215	265	192	24	36	141	8	27	22	36	141	6	24.5	48	82	192	14	51.5
125	425	235	309	215	28	42	157	8	31	24	36	151	8	27	55	82	197	16	59
140	475	245	335	240	32	58	185	10	35	28	42	167	8	31	65	105	230	18	69
160	540	290	375	272	38	58	198	10	41	32	58	198	10	35	75	105	245	20	79.5
180	600	320	435	305	42	82	232	12	45	32	58	208	10	35	85	130	285	22	90
200	665	355	489	340	48	82	247	14	51.5	38	58	223	10	41	95	130	300	25	100
224	755	390	515	384	48	82	267	14	51.5	42	82	267	12	45	100	165	355	28	106
250	830	450	594	430	60	105	315	18	64	48	82	292	14	51.5	110	165	380	28	116
280	920	500	670	480	65	105	340	18	69	55	82	317	16	59	130	200	440	32	137
315	1030	570	780	539	75	105	365	20	79.5	60	105	365	18	64	140	200	470	36	148
355	1150	600	870	605	85	130	410	22	90	70	105	385	20	74.5	170	240	530	40	179
400	1280	690	968	680	90	130	440	25	95	80	130	440	22	85	180	240	560	45	190
450	1450	750	1065	765	100	165	515	28	106	85	130	480	22	90	220	280	640	50	231
					i = 6.3 ~ 12.5					i = 14 ~ 20									
500	1600	830	1190	855	110	165	555	28	116	95	130	520	25	100	240	330	730	56	252
560	1760	910	1320	960	120	165	575	32	127	110	165	575	28	116	280	380	820	63	292
630	1980	1010	1480	1080	140	200	660	36	148	120	165	625	32	127	300	380	870	70	314
710	2220	1110	1653	1210	160	240	740	40	169	140	200	700	36	148	340	450	990	80	355

规格 Size	C	m_1	m_2	m_3	n_1	n_2	e_1	e_2	e_3	h	d_3	n	重量 kg Weight	润滑油量 L Lubrication	
112	22	160	-	180	43	85	75.5	92	134	125	15	6	60	3	
125	25	180	-	200	45	100	77.5	98	153	140			69	4.3	
140	25	200	-	210	47.5	112.5	85	106	171	160			105	6	
160	32	225	-	245	58	120	103	126	188	180	18.5	6	155	8.5	
180	32	250	-	275	60	135	110	134	209	200			18.5	185	11.5
200	40	280	-	300	65	155	117.5	148	238	225			24	260	16.5
224	40	310	-	335	70	165.5	137.5	168	263	250	24	6	370	23	
250	50	350	-	380	80	190	145	184	293	280			28	527	32
280	50	380	-	430	75	205	155	195	325	315			28	700	46
315	63	420	-	490	78	223	173	219	364	355			35	845	65
355	63	475	-	520	92.5	252.5	192.5	238	398	400	35	6	1250	90	
400	80	520	-	590	95	265	215	275	445	450			42	1750	125
450	80	-	400	650	117.5	317.5	242.5	305	505	500			42	2650	180
500	100	-	440	710	120	345	262.5	337	557	560	48	8	3400	250	
560	100	-	490	790	120	390	265	354	624	630			48	4500	350
630	125	-	540	870	115	425	295	384	694	710			56	6800	350
710	125	-	610	950	140	480	335	440	780	800			56	8509	520

YFZSY、YFZSZ减速器的装配型式及外形尺寸 YFZSY、YFZSZ Gear unit structure and outline dimension sheet

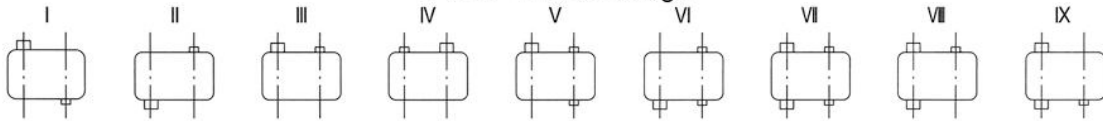
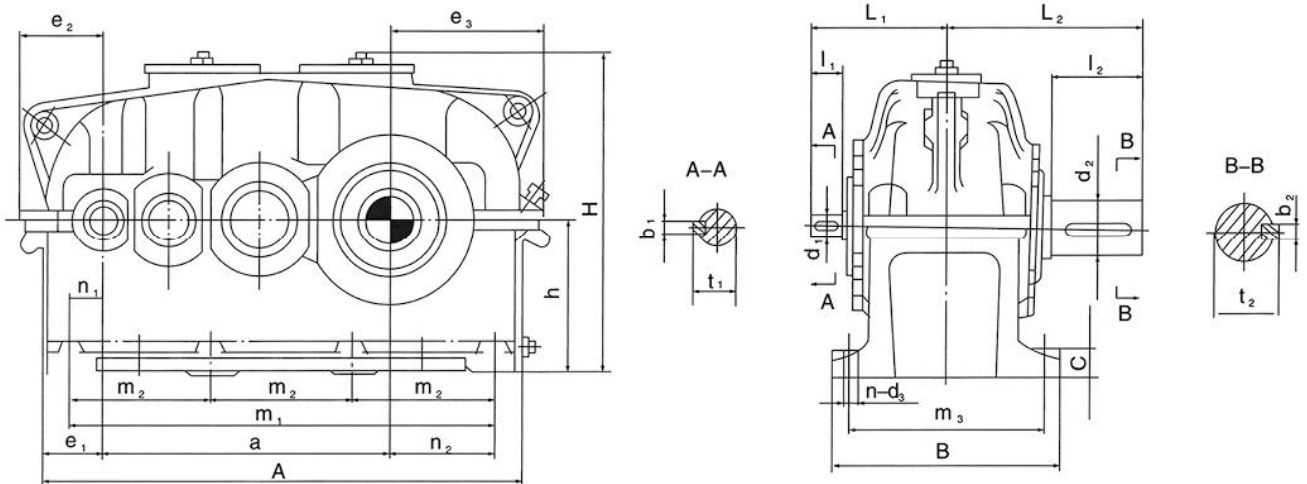

YFZSY、YFZSZ型装配型式
YFZSY、YFZSZ Design



图3

规格 Size	A	B	H ≈	a	i= 22.4 ~ 71					i= 80 ~ 100					d ₂ (m ₆)	l ₂	L ₂	b ₂	t ₂
					d ₁ (m ₆)	l ₁	L ₁	b ₁	t ₁	d ₁ (m ₆)	l ₁	L ₁	b ₁	t ₁					
160	600	290	375	352	24	36	166	8	27	19	28	158	6	21.5	75	105	245	20	79.5
180	665	320	435	395	28	42	187	8	31	22	36	181	6	24.5	85	130	285	22	90
200	745	355	492	440	32	58	218	10	35	22	36	196	6	24.5	95	130	300	25	100
224	840	390	535	496	38	58	233	10	41	24	36	211	8	27	100	165	355	28	106
250	930	450	589	555	42	82	282	12	45	32	58	258	10	35	110	165	380	28	116
280	1025	500	662	620	48	82	307	14	51.5	38	58	283	10	41	130	200	440	32	137
315	1160	570	749	699	48	82	337	14	51.5	42	82	337	12	45	140	200	470	36	148
					i= 22.4 ~ 35.5					i= 40 ~ 90									
355	1280	600	870	785	60	105	380	18	64	48	82	357	14	51.5	170	240	530	40	179
400	1420	690	968	880	65	105	410	18	69	55	82	387	16	59	180	240	560	45	190
450	1610	750	1067	989	70	105	450	20	74.5	60	105	450	18	64	220	280	640	50	231
					i= 22.4 ~ 45					i= 50 ~ 90									
500	1790	830	1170	1105	80	130	515	22	85	65	105	490	18	69	240	330	730	56	252
560	2010	910	1320	1240	95	130	530	25	100	75	105	505	20	79.5	280	380	820	63	292
630	2260	1030	1480	1395	110	165	625	28	116	85	130	590	22	90	300	380	880	70	314
710	2540	1110	1655	1565	120	165	685	32	127	90	130	650	25	95	340	450	1010	80	355

规格 Size	C	m ₁	m ₂	m ₃	n ₁	n ₂	e ₁	e ₂	e ₃	h	d ₃	n	重量 kg Weight	润滑油量 L Lubrication
160	32	510	170	245	38	120	83	107	188	180	18.5	8	170	10
180	32	570	190	275	37.5	137.5	85	109	209	200	18.5	8	205	14
200	40	630	210	300	40	150	97.5	128	238	225	24	8	285	19
224	40	705	235	335	43.5	165.5	110.5	141	263	250	24	8	395	26
250	50	810	270	380	60	195	120	158	293	280	28	8	540	36
280	50	855	285	430	35	200	120	160	325	315	28	8	750	53
315	63	960	320	490	40	218	143	189	364	355	35	8	940	75
355	63	1080	360	520	42.5	252.5	143	188	398	400	35	8	1400	115
400	80	1200	400	590	45	275	155	215	445	450	42	8	1950	160
450	80	1350	450	650	48	318	178	240	505	500	42	8	2636	220
500	100	1500	500	710	57.5	337.5	202.5	277	557	560	48	8	3800	300
560	100	1680	560	790	70	370	235	324	624	630	48	8	5100	450
630	125	1890	630	890	72.5	422.5	255	344	694	710	56	8	7060	520
710	125	2130	710	1000	92.5	472.5	297.5	400	780	800	56	8	9205	820

YFZFY 减速器的装配型式及外形尺寸
YFZFY Gear unit structure and outline dimension sheet

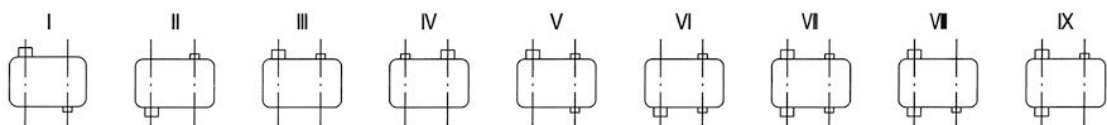

图4

规格 Size	L	B	h ₁	轴 Shaft								A	A ₁	L ₃	L ₄ ≈	L ₅ ≈	G ₁
				d ₁	L ₁	d ₁	L ₁	d ₁	L ₁	d ₂	L ₂						
				i=112-280		i=315-500											
160	665	320	32	16k6	30	14k6	30	-	-	85m6	140	395	63	85	109	209	145
180	745	355	40	19k6	35	16k6	30	-	-	95m6	160	440	70	97.5	128	238	160
200	845	390	40	22k6	35	19k6	35	-	-	100m6	180	497	80	110.5	141	263	170
250	930	450	50	24k6	40	22k6	35	-	-	110n6	180	555	90	120	158	293	190
280	1025	500	50	28m6	90	24k6	40	-	-	130n6	210	620	100	120	160	325	210
315	1160	570	63	32m6	60	28m6	50	-	-	140n6	240	705	112	140	189	364	230
				i=100-140		i=160-250		i=280-500									
355	1280	600	63	38m6	60	32m6	90	28m6	50	170n6	270	790	125	140	188	398	255
400	1420	690	80	42m6	70	38m6	90	32m6	60	180n6	310	880	140	155	215	445	290
450	1610	750	80	48m6	80	42m6	70	38m6	60	210n6	350	995	160	175	240	505	320
				i=100-190		i=180-250		i=280-500									
500	1740	830	100	48m6	80	42m6	70	38m6	60	240n6	400	1110	180	200	277	557	355
560	2010	910	100	60m6	105	55m6	60	48m6	80	270n6	450	1240	200	235	324	624	400
630	2260	1030	125	65m6	105	60m6	105	48m6	80	300n6	500	1400	225	255	344	694	450
710	2540	1160	125	75m6	120	65m6	105	55m6	90	340n6	550	1570	250	295	400	780	500

规格 Size	G ₂	H ₁	H ₀	H _≈	L ₆	L ₇	B ₁	L ₈	L ₉	b	数量 Qty	重量 kg Weight	润滑油量 L Lubrication
160	155	137	200	415	570	190	275	47.5	137.5	M16	8	205	16
180	170	155	225	462	630	210	300	57.5	150	M20	8	290	21
200	190	170	250	511	705	235	335	67.5	165	M20	8	400	29
250	215	190	280	570	810	270	380	60	195	M24	8	550	40
280	240	215	315	644	855	285	430	85	200	M24	8	760	58
315	270	243	355	716	960	320	490	100	215	M30	8	1100	82
355	290	275	400	806	1080	360	520	100	250	M30	8	1450	140
400	320	310	450	906	1200	400	590	110	275	M36	8	2000	185
450	360	340	500	1006	1350	450	650	130	310	M36	8	2700	260
500	400	380	560	1121	1500	500	710	145	335	M42	8	3900	260
560	440	430	630	1261	1680	560	790	165	370	M42	8	5200	530
630	500	485	710	1406	1890	630	860	185	420	M48	8	7300	570
710	560	550	800	1581	2130	710	1000	205	470	M48	8	9900	900

YFDBY、YFDBZ减速器的装配型式及外形尺寸
YFDBY、YFDBZ Gear unit strcture and outine dimension sheet

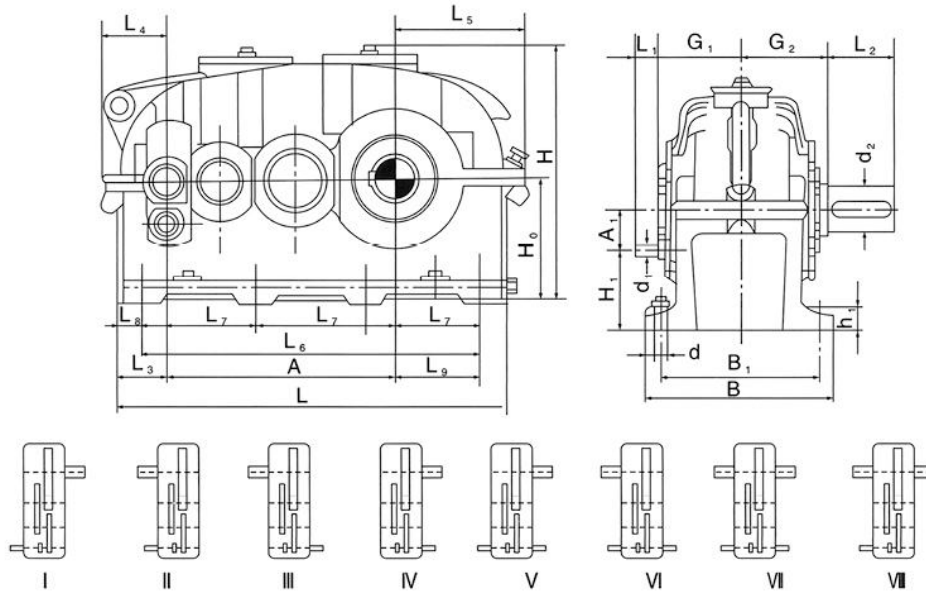
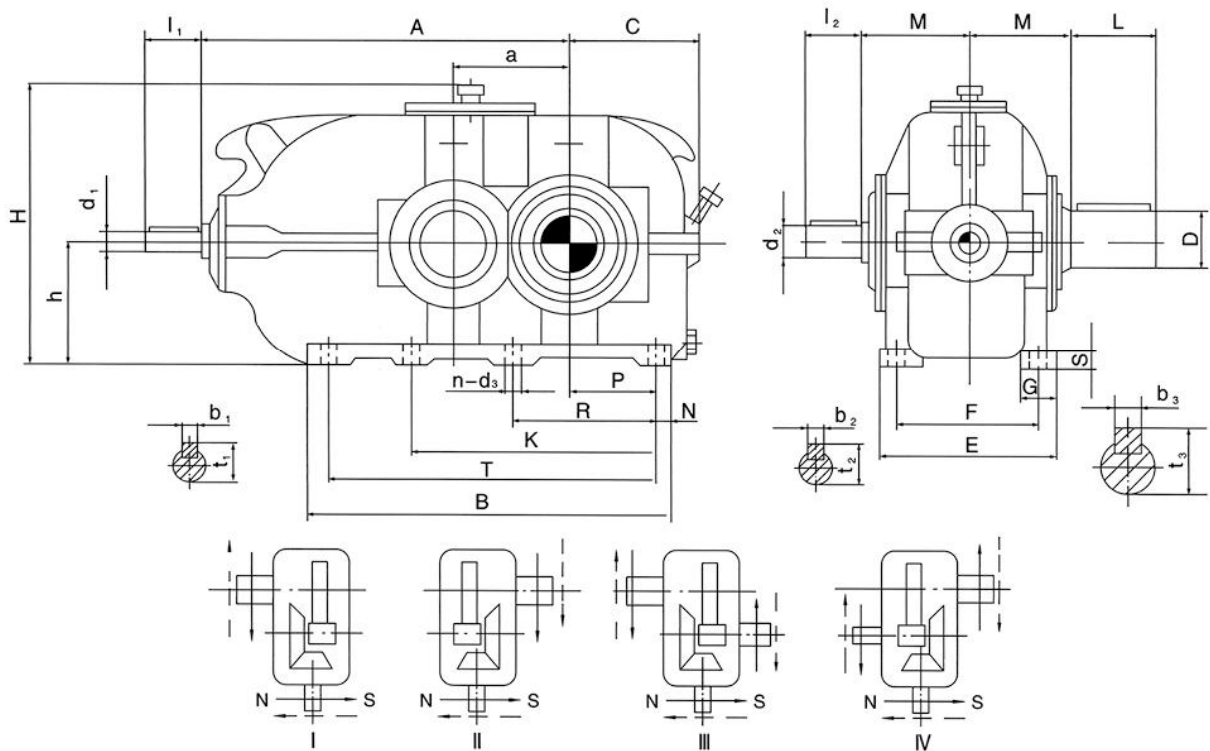

YFDBY、YFDBZ型装配型式 图5
YFDBY、YFDBZ Design

mm

名义中心距a Centre height	d ₁	l ₁	d ₂	l ₂	D	L	A	B	C	E	F	G	S	h	H	M
160	40	110	48	110	70	140	500	500	190	250	210	65	35	180	430	145
180	42		50		80	170	565	565	215	270	230	70		200	475	160
200	50		55		90		625	625	240	300	250	75	40	225	520	175
224	55	140	65	140	100	210	705	705	260	320	270	80	45	250	570	190
250	60		75		110		785	785	290	370	310	90	50	280	626	210
280	65		85		170		120	875	875	325	400	340	100	55	315	702
315	75	95	140	250		975	975	355	450	380	110	60	355	809	260	
355	90	170	100	210	160	300	1085	1085	390	480	410	120	65	400	900	285
400	100	210	110		170		1215	1215	440	530	460	130	70	450	970	305
450	110		130	250	190	350	1365	1365	490	600	510	140	80	500	1071	345
500	120		150		220		1525	1525	570	650	560	150	90	560	1210	435
560	130	250	160	300	250	410	1705	1705	610	750	640	160	100	630	1325	475

315

名义中心距a Centre height	n-d ₃	N	P	R	K	T	b ₁	t ₁	b ₂	t ₂	b ₃	t ₃	重量 kg Weight	润滑油量L Lubrication	图号 Sheet
160	6-18	30	115	210	-	440	12	43	14	51.5	20	74.5	173	7	DBY160.0(DBZ160.0)
180			135	240		505		45		53.5	22	85	232	9	DBY180.0(DBZ180.0)
200	6-23	35	145	255		555	14	53.5	16	59	25	95	305	13	DBY200.0(DBZ200.0)
224			165	290		635	16	59	18	69	28	106	415	18	DBY224.0(DBZ224.0)
250	6-27	40	180	315		705	18	64	20	79.5		116	573	25	DBY250.0(DBZ250.0)
280		45	200	355		785		69	22	90	32	127	760	36	DBY280.0(DBZ280.0)
315	6-33	50	220	405		875	20	79.5	25	100	36	148	1020	51	DBY315.0(DBZ315.0)
355		55	245	450		975	25	95	28	106	40	169	1436	69	DBY355.0(DBZ355.0)
400			280	510		1105	28	106		116		179	1966	95	DBY400.0(DBZ400.0)
450	8-39	60	315	575		940		1245	32	116	32	137	45	200	2532
500		70	350	645	1050	1385	127	36		158	50	231	3633	185	DBY500.0(DBZ500.0)
560		80	390	715	1165	1545	137	40		169	56	262	5020	260	DBY560.0(DBZ560.0)

YFDBYK 减速器的装配型式及外形尺寸
YFDBYK Gear unit structure and outline dimension sheet

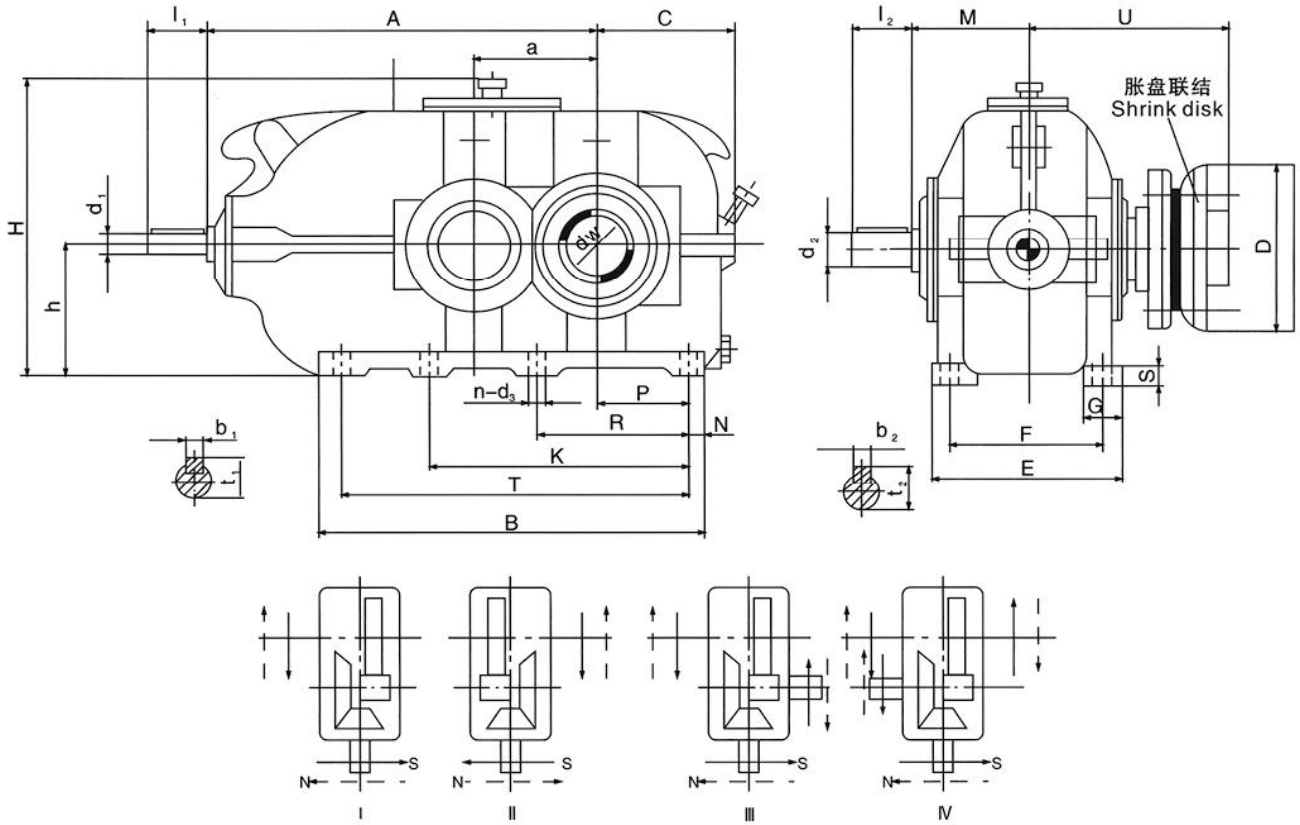

YFDBYK型装配型式
YFDBYK Design
图6

名义中心距a Centre height	d_1	I_1	d_2	I_2	dw	U	A	B	C	E	F	G	S	h	H	M
160	40	110	48	110	80	225	500	500	190	250	210	65	35	180	430	145
180	42		50		90	250	565	565	215	270	230	70		200	475	160
200	50		55	100	275	625	625	240	300	250	75	40	225	520	175	
224	55		65	110	295	705	705	260	320	270	80	45	250	570	190	
250	60	140	75	140	120	325	785	785	290	370	310	90	50	280	626	210
280	65		85	135	360	875	875	325	400	340	100	55	315	702	230	
315	75		95	160	420	975	975	355	450	380	110	60	355	809	260	
355	90	170	100	210	180	450	1085	1085	390	480	410	120	65	400	900	285
400	100	110	200		490	1215	1215	440	530	460	130	70	450	970	305	
450	110	210	130	250	220	550	1365	1365	490	600	510	140	80	500	1071	345
500	120		150		280	715	1525	1525	570	650	560	150	90	560	1210	435
560	130		250	160	300	310	760	1705	1705	610	750	640	160	100	630	1325

YFZDY/YFDBY系列 | 外形安装尺寸

Outside dimension sheets-overview

名义中心距 Centre height	$n-d_3$	N	P	R	K	T	b_1	t_1	b_2	t_2	D	重量 kg Weight	润滑油量 L Lubrication	图号 Sheet	
160	6-18	30	115	210	-	440	12	43	14	51.5	185	173	7	DBYK160.0	
180			135	240		505		45		53.5	215	232	9	DBYK180.0	
200	6-23	35	145	255		555	14	53.5	16	59	230	305	13	DBYK200.0	
224			165	290		635	16	59	18	69	263	415	18	DBYK224.0	
250	6-27	40	180	315		705	18	64	20	79.5	290	573	25	DBYK250.0	
280			200	355		785		69	22	90	300	760	36	DBYK280.0	
315	6-33	50	220	405		875	20	79.5	25	100	370	1020	51	DBYK315.0	
355			55	245		450	975	25	95	28	106	405	1436	69	DBYK355.0
400				280		510	1105		106		116	430	1966	95	DBYK400.0
450	8-39	60	315	575		940	1245	28	116	32	137	460	2532	130	DBYK450.0
500			350	645	1050	1385	32		127	36	158	570	3633	185	DBYK500.0
560	8-45	80	390	715	1165	1545		137	40	169	660	5020	260	DBYK560.0	

注：承载能力及选用方法与DBY型相同。

YFDCY、YFDCZ 减速器的装配型式及外形尺寸

YFDCY、YFDCZ Gear unit structure and outline dimension sheet

317

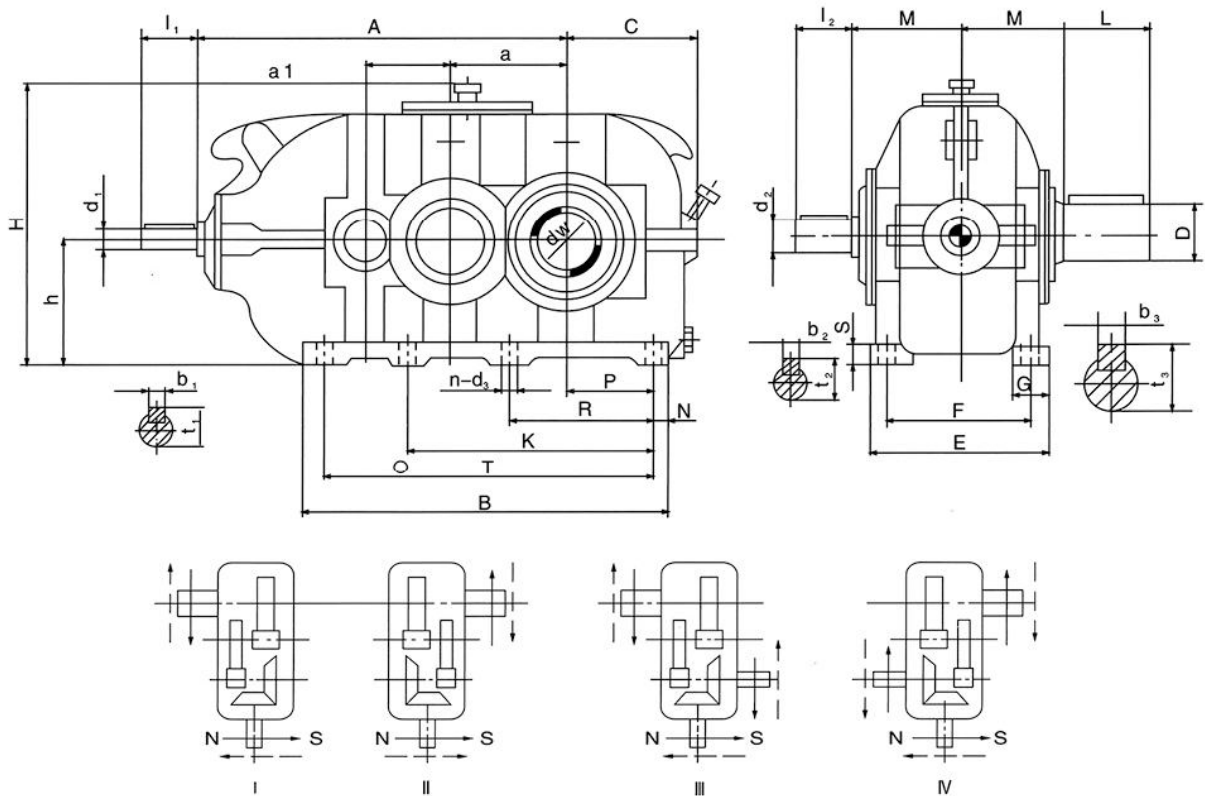

YFDCY、YFDCZ型装配型式
YFDCY、YFDCZ Design
图7

外形安装尺寸 | YFZDY/YFDBY系列
Outside dimension sheets-overview

名义中心距a Centre height	a ₁	d ₁	l ₁	d ₂	l ₂	D	L	A	B	C	E	F	G	S	h	H	M
160	112	25	60	32	80	70	140	510	555	190	250	210	65	35	180	423	145
180	125	30	80	38		80	170	575	625	215	270	230	70		200	468	160
200	140	35		42	110	90		640	685	240	300	250	75	40	225	520	175
224	160	40	48	100		725	775	260	320	270	80	45	250	570	190		
250	180	42	50	110		210	815	860	290	370	310	90	50	280	626	210	
280	200	50	55	140	120	905	970	325	400	340	100	55	315	702	230		
315	224	55	65		140	140	250	1020	1085	355	450	380	110	60	355	809	260
355	250	60	75	170	160	300	1140	1220	390	480	410	120	65	400	900	285	
400	280	65	85		170		170	1275	1355	440	530	460	130	70	450	970	305
450	315	75	95	210	190	350	1425	1520	490	600	510	140	80	500	1065	345	
500	355	90	100		210		220	1585	1690	570	650	560	150	90	560	1208	435
560	400	100	110	250	250	410	1775	1895	610	750	640	160	100	630	1325	475	
630	450	110	130		250	300	470	1995	2145	675	800	690	170	110	710	1460	525
710	500	120	150	300	340	550	2235	2400	760	900	770	190	125	800	1665	570	
800	560	130	250		160	400	650	2505	2700	840	1000	870	200	140	900	1870	625

名义中心距a Centre height	n-d ₃	N	P	R	K	T	b ₁	t ₁	b ₂	t ₂	b ₃	t ₃	重量 kg Weight	润滑油量L Lubrication	图号 Sheet
160	6-18	30	115	210	-	495	8	28	10	35	20	74.5	200	9	DCYT160.0(DCZ160.0)
180			135	240		565		33		41	22	85	255	13	DCYT180.0(DCZ180.0)
200	6-23	35	145	255	615	10	38	12	45	25	95	325	18	DCYT200.0(DCZ200.0)	
224			165	290	705	12	43	14	51.5	28	106	453	26	DCYT224.0(DCZ224.0)	
250	6-27	40	180	315	780	12	45	14	53.5	28	116	586	33	DCYT250.0(DCZ250.0)	
280			45	200	355	880	14	53.5	16	59	32	127	837	46	DCYT280.0(DCZ280.0)
315	8-33	50	220	405	655	985	16	59	18	69	36	148	1100	65	DCYT315.0(DCZ315.0)
355			245	450	740	1110	18	64	20	79.5	40	169	1550	90	DCYT355.0(DCZ355.0)
400	55	280	510	840	1245	18	69	22	90	40	179	1967	125	DCYT400.0(DCZ400.0)	
450	8-39	60	315	575	940	1400	20	79.5	25	100	45	200	2550	180	DCYT450.0(DCZ450.0)
500			70	350	645	1050	1550	25	95	28	106	80	231	4340	240
560	8-45	80	390	715	1165	1735	28	106	28	116	56	262	5320	335	DCYT560.0(DCZ560.0)
630			445	800	1305	1985	28	116	32	137	70	314	7170	480	DCYT630.0(DCZ630.0)
710	90	90	500	900	1490	2220	32	127	36	158	80	355	9600	690	DCYT710.0(DCZ710.0)
800			560	1100	1680	2520	32	137	40	169	90	417	13340	940	DCYT800.0(DCZ800.0)

YFDCYK 减速器的装配型式及外形尺寸
YFDCYK Gear unit strcture and outine dimension sheet

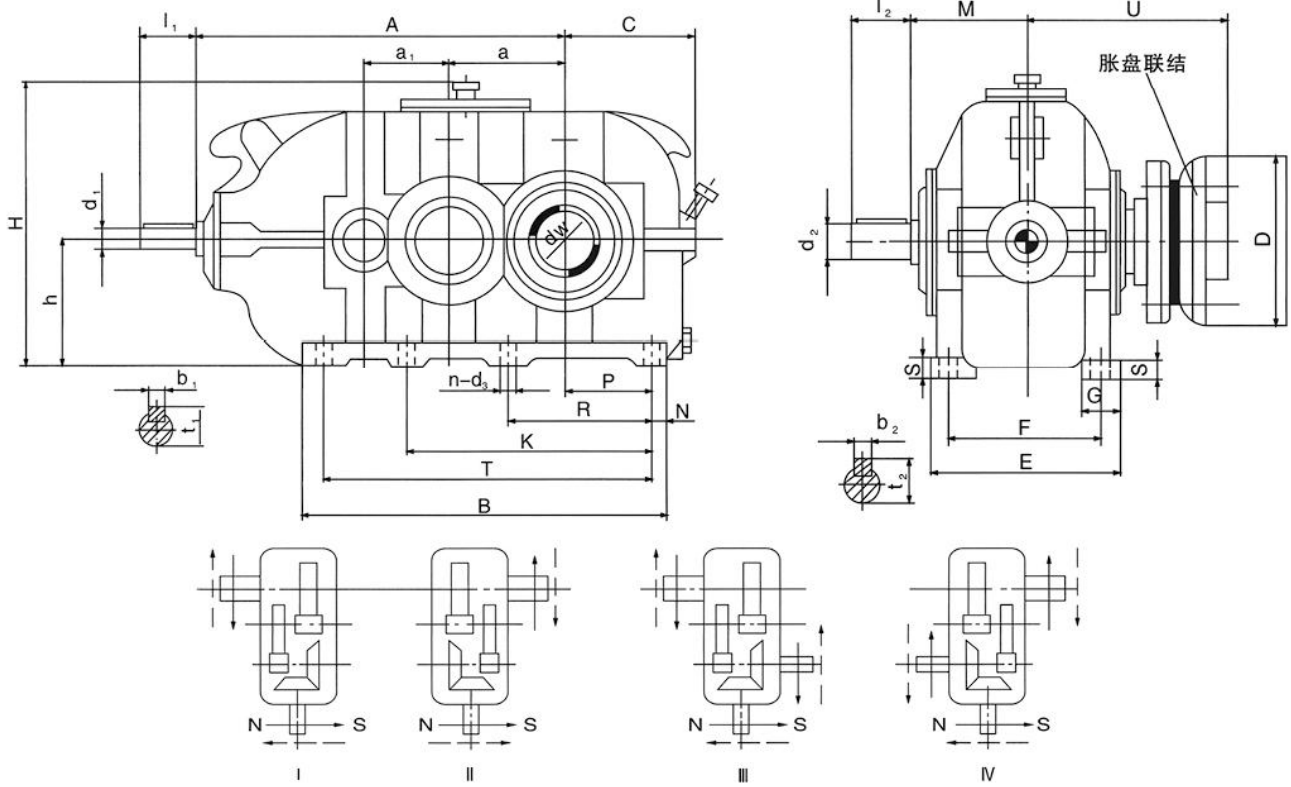

YFDCYK型装配型式
YFDCYK Design

图8

名义中心距a Centre height	a_1	d_1	I_1	d_2	I_2	dw	U	A	B	C	E	F	G	S	h	H	M
160	112	25	60	32	80	80	225	510	555	190	250	210	65	35	180	423	145
180	125	30	80	38		90	250	575	625	215	230	270	70		200	468	160
200	140	35		110	42	110	100	275	640	685	240	250	300	75	40	225	520
224	160	40	48		110		110	295	725	775	260	270	320	80	45	250	570
250	180	42	110	50	140	120	325	815	860	290	310	370	90	50	280	626	210
280	200	50		55		135	360	905	970	325	340	400	100	100	55	315	702
315	224	55	140	65	140	160	420	1020	1085	355	380	450	110	60	355	809	260
355	250	60		75		180	450	1140	1220	390	410	480	120	65	400	900	285
400	280	65	140	85	170	200	490	1275	1355	440	460	530	130	70	450	970	305
450	315	75		95		220	550	1425	1520	490	510	600	140	80	500	1065	345
500	355	90	170	100	210	280	715	1585	1690	570	560	650	150	90	560	1208	435
560	400	100		110		310	760	1775	1895	610	640	750	160	100	630	1325	475
630	450	110	210	130	250	340	840	1995	2145	675	690	800	170	110	710	1460	525
710	500	120		150		380	890	2235	2400	760	770	900	190	125	800	1665	570
800	560	130	250	160	300	420	955	2505	2700	840	870	1000	200	140	900	1870	625

名义中心距a Centre height	n-d ₃	N	P	R	K	T	b ₁	t ₁	b ₂	t ₂	D	重量 kg Weight	润滑油量L Lubrication	图号 Sheet
160	6-18	30	115	210		495	8	28	10	35	185	200	9	DCYK160.0
180			135	240		565		33		41	215	255	13	DCYK180.0
200	6-23	35	145	255		615	10	38	12	45	230	325	18	DCYK200.0
224			165	290		705		43		51.5	263	453	26	DCYK224.0
250	6-27	40	180	315		780	12	45	14	53.5	290	586	33	DCYK250.0
280			200	355		880		53.5		16	59	300	837	46
315	8-33	50	220	405	655	985	16	59	18	69	370	1100	65	DCYK315.0
355			245	450	740	1110		18		64	20	79.5	405	1550
400		280	510	840	1245	18	69	22	90	430	1967	125	DCYK400.0	
450	8-39	60	315	575	940	1400	20	79.5	25	100	460	2675	180	DCYK450.0
500			350	645	1050	1550		25		95	28	106	570	4340
560	8-45	80	390	715	1165	1735	28	106	28	116	660	5320	335	DCYK560.0
630			445	800	1305	1985		116		32	137	690	7170	480
710		90	500	900	1490	2220	32	127	36	158	770	9600	690	DCYK710.0
800			560	1100	1680	2520		137		40	169	850	13340	940

注：承载能力及选用方法与DCY型相同。

附录

YFDBY、YFDCYK型减速器空心轴套及联接结构（参考）尺寸
YFDBY、YFDCYK Gear unit Hollow shaft and coupling



图9

表13 胀盘联接的轴尺寸
Table13 shaft for shrind disks dimension

名义中心距 Centre height	a	$d_{M(min)}$	dw	d_1	L	L_1	L_2	R
160	5	100	80	78	355	65	90	1.6
180	5	110	90	88	395	70	100	1.6
200	5	125	100	98	430	75	110	1.6
224	5	135	110	108	465	80	120	1.6
250	6	150	120	118	510	90	130	2.5
280	6	165	135	133	565	100	140	2.5
315	6	190	160	158	655	120	160	2.5
355	6	210	180	178	710	125	170	2.5
400	8	240	200	198	765	145	190	4
450	8	260	220	218	860	150	200	4
500	10	320	280	278	1145	240	290	4
560	10	350	310	308	1225	260	310	4
630	12	380	340	338	1355	280	330	6
710	12	430	380	378	1440	300	350	6
800	12	470	420	418	1550	320	380	6

mm

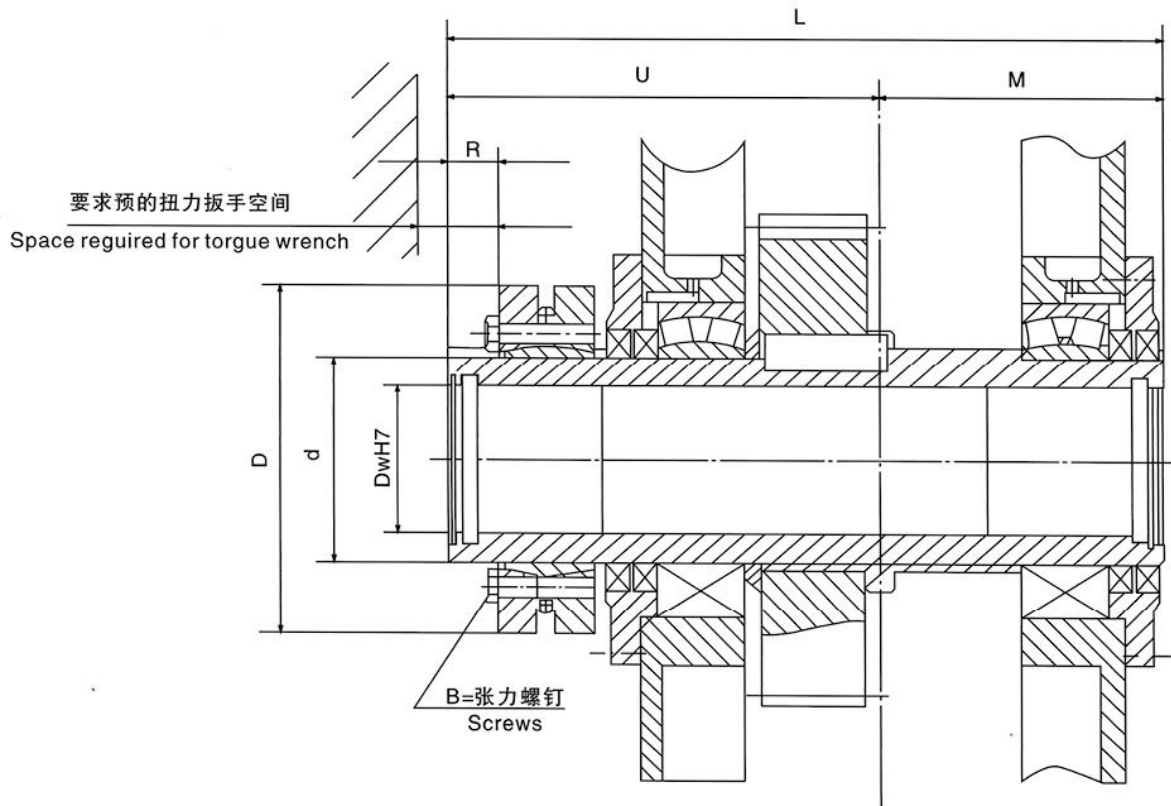
注：dw≥160mm时配合公差采用g6

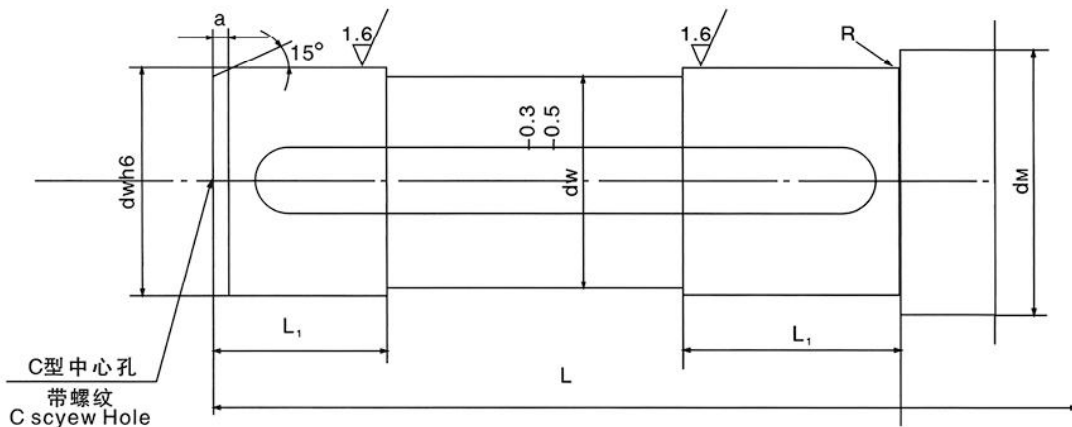

图11平键联接的轴
Sheet11: shaft for parallel dey connections